

FK37 JEEP JK PANHARD EXTENSION BRACKET AND BUMP STOP SPACER KIT (TO SUIT LEFT HAND DRIVE)

Part Number	Description	Quantity
COMPONENTS TO FIT BUMP STOP SPACERS		
1	3757564 Bump stop spacer bracket	2
2	6151021 Bolt M8 x 1.25P x 20	4
3	6151132 Nut M8 x 1.25 flange	4
4	4581044 Washer 8mm flat	4

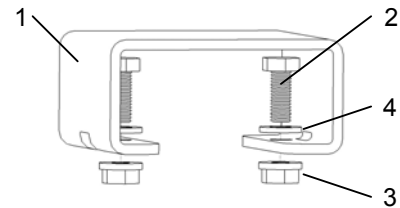

COMPONENTS TO FIT PANHARD EXTENSION BRACKET		
5	3757565R Panhard extension bracket	1
6	3199971 Panhard extension tension plate	1
7	5848346 Long extension bracket packer	1
8	6151258 Bolt M14 x 1.5P x 80	2
9	6151410 Nut M14 x 1.5P nyloc	2
10	4584298 Washer 14mm flat	4
11	6151094 Bolt M12 x 1.25P x 30	2
12	6151135 Nut M12 x 1.25P	2
13	4581064 Washer 12mm spring	2
14	4581049 Washer 12 mm flat	2

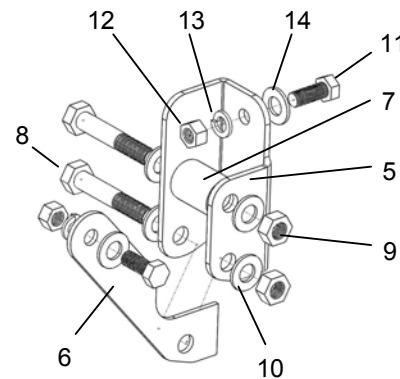

BUMP STOP SPACER FITMENT



1. Fit 2 M8 x 20 bolts with flat washers to bump stop plate from underside as shown.



2. Fit bump stop spacer bracket over bolts and secure with flange nuts.

Tip: Secure nuts finger tight and then tighten bolt with spanner from below. Flange nuts will bite into bracket and will not spin.

BUMP STOP SPACERS MUST BE FITTED WITH PANHARD RELOCATION BRACKET OR BRACKET WILL COLLIDE WITH SHOCK ABSORBER BODY AT FULL COMPRESSION OF SUSPENSION.

PANHARD ROD EXTENSION BRACKET FITMENT

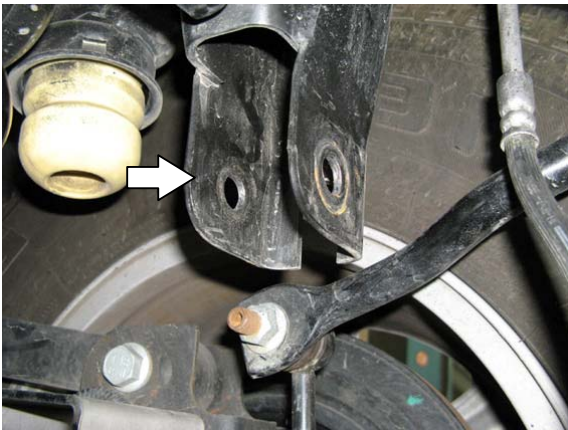

1. Remove bolt securing upper end of panhard rod and remove panhard rod from mount.



2. Fit spacer tube between panhard rod mount as shown.



3. Fit panhard rod extension bracket as shown.



4. Fit M14 x 80mm bolt with flat washer through bracket, original mount and spacer tube as shown.



5. Fit M14 x 80mm bolt with flat washer through bracket lower hole. Fit 4mm thick washer to inside of bracket.

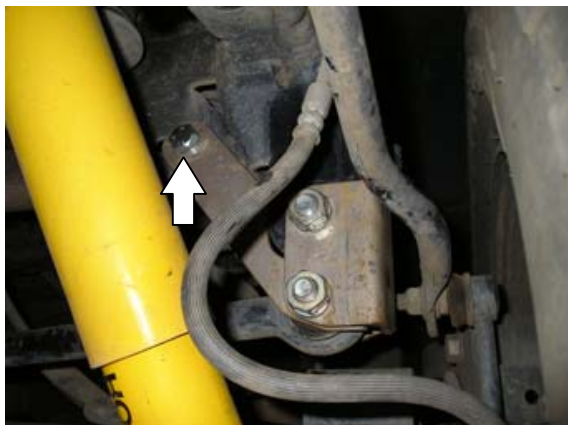

6. Fit tension member to chassis using M12 x 30mm bolt, nut and washers as shown.



7. Locate panhard rod between tension member and 4mm thick washer inside panhard rod extension bracket.
8. Secure with M14 bolt using flat washer and nyloc nut as shown.



9. Remove wheel as per manufacturers instructions.
10. Using the hole in the extension bracket as a guide, drill a 8mm pilot hole through the original mount.
11. Drill the hole out the 12mm and secure with M12 x 20 bolt, flat washer and flange nut.



12. Torque this bolt to 40 ft.lbs (54 Nm).
13. Refit wheel as per manufacturers instructions.
14. Tighten all bolts to the following torque values.

M14: 63 ft.lbs (85 Nm)

M12: 40 ft.lbs (54 Nm)



Optional winch compatible bull bar shown.