



RHINO-RACK®

TOYOTA Landcruiser 300 Backbone RTL B5

Important:

1. Check the Rhino-Rack website to ensure you have the latest issue of these instructions.
2. Please refer to your fitting instruction to ensure that the roof racks are installed in the correct locations.
3. Check the contents of kit before commencing fitment and report any discrepancies.
4. Place these instructions in the vehicle's glove box after installation is complete.
5. These instructions must be followed for warranty to be upheld.

Fit Time: 3 hours

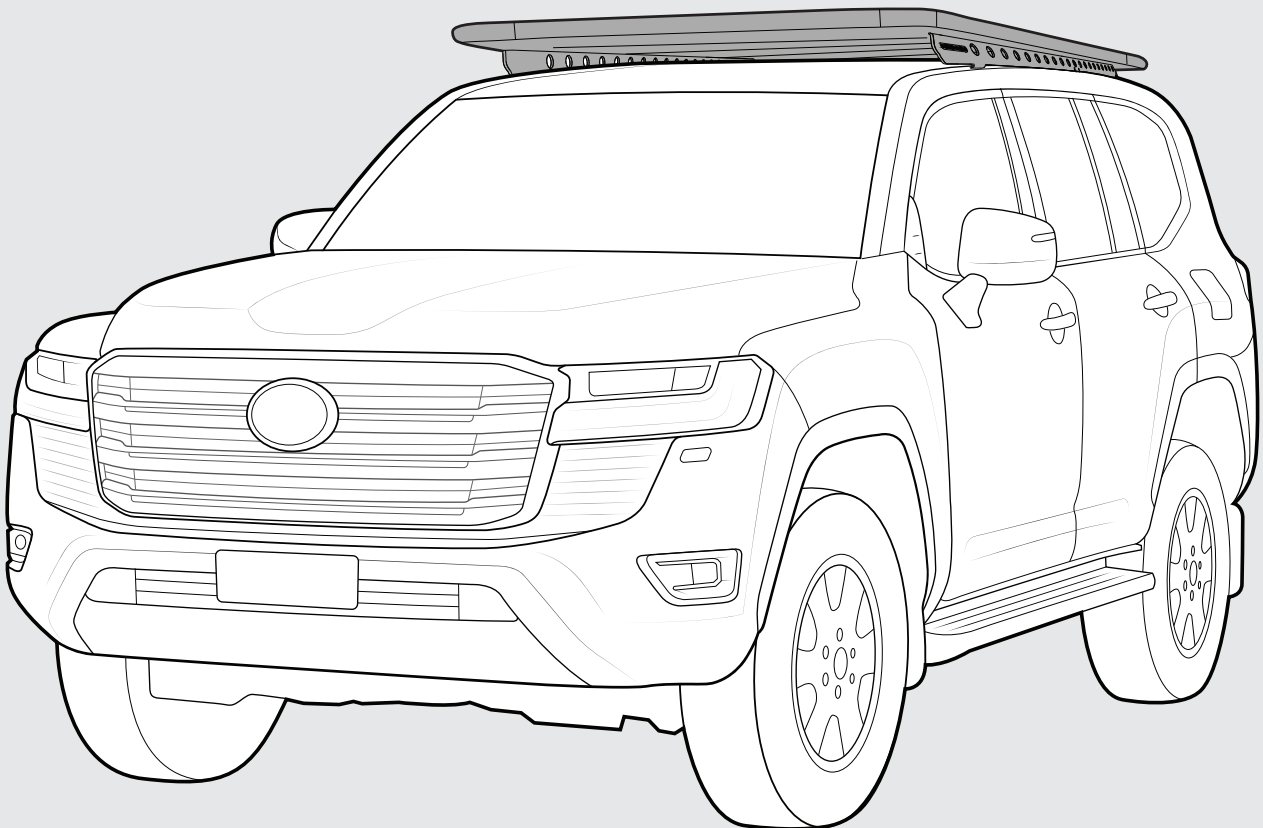

Rhino-Rack AUSTRALIA
22A Hanson Pl,
Eastern Creek, NSW, 2766
(02) 8846 1900
rhinorack.com.au

Rhino-Rack USA
Unit D, 2450 Airport Blvd,
Aurora, CO, 80011
877-744-6622
rhinorack.com

Document No: 520-RFI-00060
Issue No: 04
Issue Date: 03/02/2022

RTL B5 Backbone Instructions

Carrying Capacity

Check the website and the vehicle owners hand book for your vehicle manufacturer's maximum carrying capacity. Load must be evenly distributed over the system.

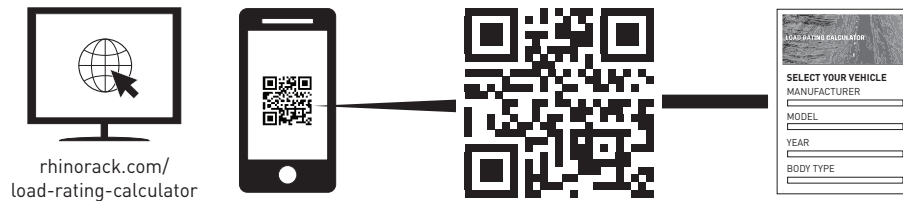

Cargo Load Limit

Total permissible weight allowed on top, and attached to the rack whilst the vehicle is in motion.

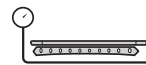

System Weight

Total weight of the rack system. (e.g. Crossbars, Backbone, Platform)



Max System Load Capacity

Please ensure you use the vehicle manufacturer's maximum roof allowance if it is lower than the figure listed in the fitting chart/supplement.



Vehicle Manufacturer's Load Limit

Total permissible weight attached to the rack. This is inclusive of the weight of the rack system.

Warning

- Check part number or kit is correct for use with your vehicle.
- Do not attempt to fit the rack system to your vehicle unless you fully understand these fitting instructions. Please direct any questions regarding fitting to the dealer from where the roof racks were purchased.
- Off-road conditions can be much more rigorous. Extreme care must be taken on any driven path that does not contain a surface protection layer (tar/bitumen).
- Racks must be removed when vehicle is put through an automatic car wash.
- With utility/pick up vehicles, the cabin and the utility tray/truck bed move independently. Racks and vehicle can be damaged if the item transported is rigidly fixed at points on both the cabin and utility tray/truck bed. Instead, rigidly fix to either the utility tray/bed racks or the canopy roof racks.
- Always ensure you fasten your load securely.
- Use only non-stretch fastening ropes or straps to attach cargo to your load.

In service maintenance checks

- All bolt connections should be checked after driving a short distance when you first install your roof racks.
- All bolted connections should be checked again at regular intervals (weekly is recommended, depending on road conditions, usage, loads and distances travelled).
- All bolted connections should be checked each time they are re-fitted.
- Off-road conditions are more rigorous. Check all bolted connections and your load more regularly.
- Ensure that your vehicle manufacturer's GVM, and gross axle weights are not exceeded (refer to vehicle owner's manual).

Torque Settings:

Unless stated otherwise in these instructions, all fasteners should be set to the following torque settings:



Note for Dealers and Fitters

It is your responsibility to ensure these fitting instructions are given to the end user or client. These instructions remain the property of Rhino-Rack Australia Pty. Ltd. and may not be used or changed for any other purpose than intended.

RTL B5 Backbone Instructions

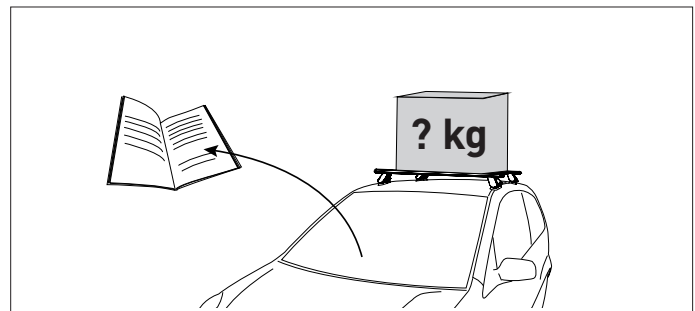
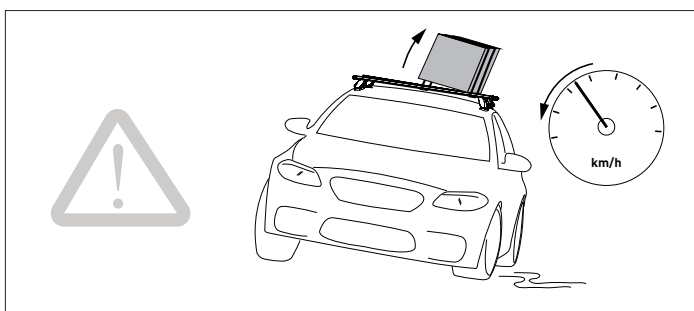
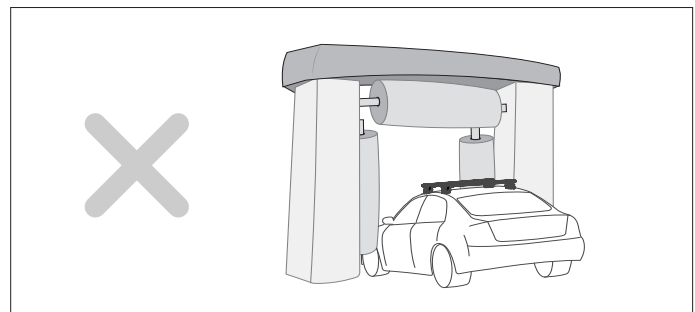
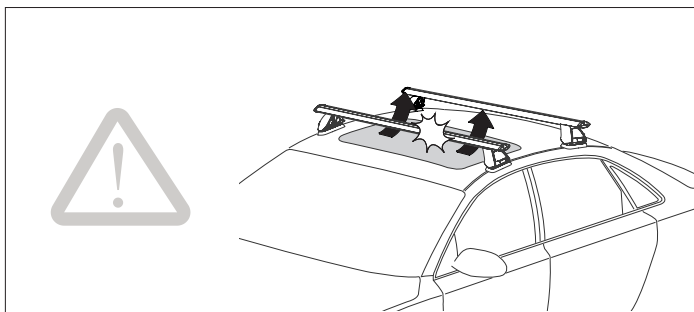
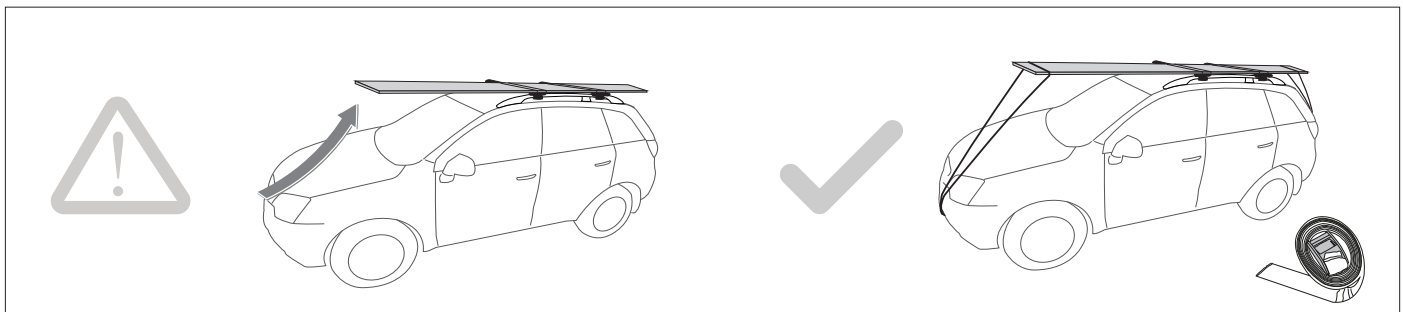

The handling characteristics of the vehicle changes when a load is transported on the roof. Exercise extreme care when transporting wind-resistant loads. Special consideration must be taken when cornering and braking.

Off-road conditions can be much more rigorous. Extreme care must be taken in off-road conditions.

Ensure Ladder is well supported on the ground to support tent. Take extreme caution when climbing heights above 1.2m/4ft.

Paddle/ Surfboards should be fixed to the front of the vehicle.

RTL5 Backbone Instructions

Parts List

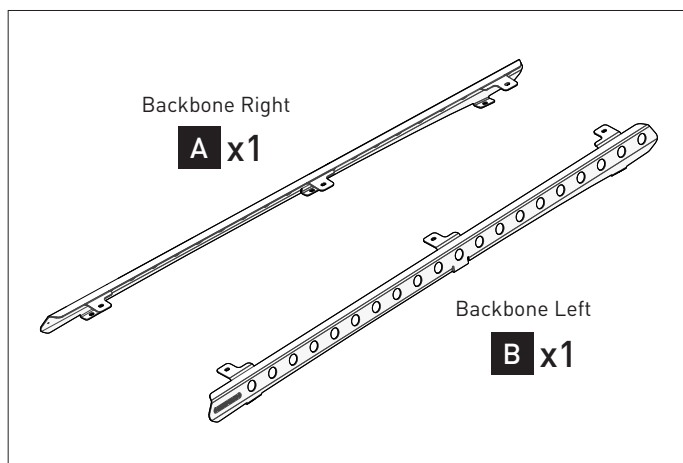

Tools Required:

- T1 - Pointed Trim Tool
- T2 - Trim Tool
- T3 - 10mm Socket Wrench
- T4 - 12mm Socket Wrench
- T5 - 13mm Socket Wrench / Spanner
- T6 - Cleaning Rag

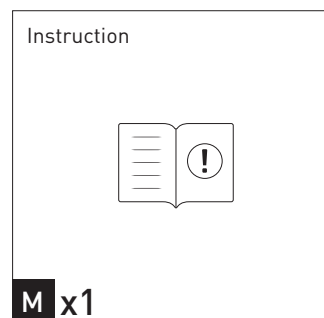
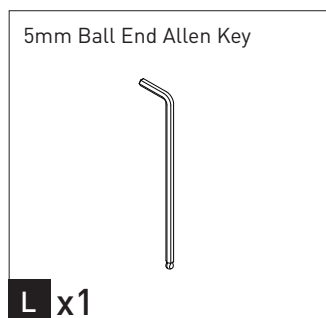
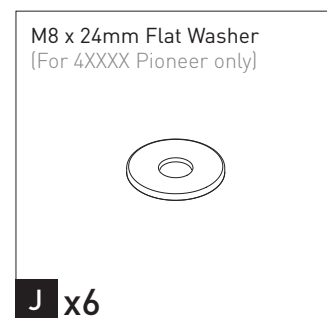
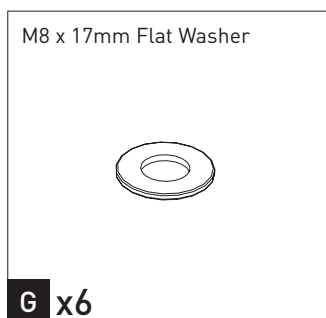
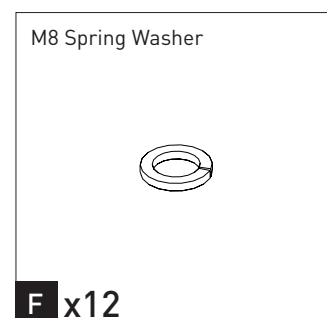
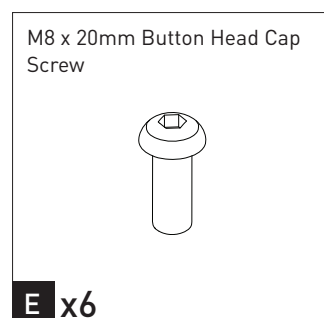
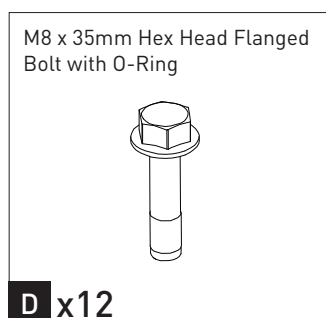
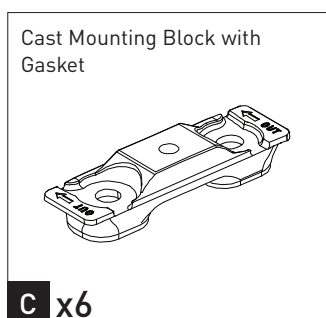

CONTENTS:

For **Factory Rail Variants**, complete Steps **1** - **11** and **14** - **23**

For **Bare Roof Variant**, complete Steps **12** - **23**

FACTORY RAIL REMOVAL (For Bare Roof Variant, skip to Step 12)

1 Remove rail end caps.

1a Press pointed trim tool **T1** into the gap between rail body and end cap, to create space for second trim tool.

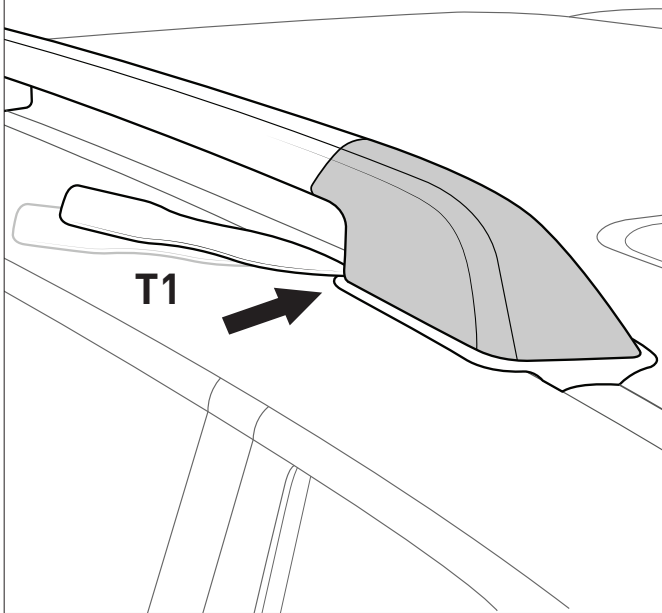

1b Slide a second trim tool **T2** between the rubber seal and end cap.

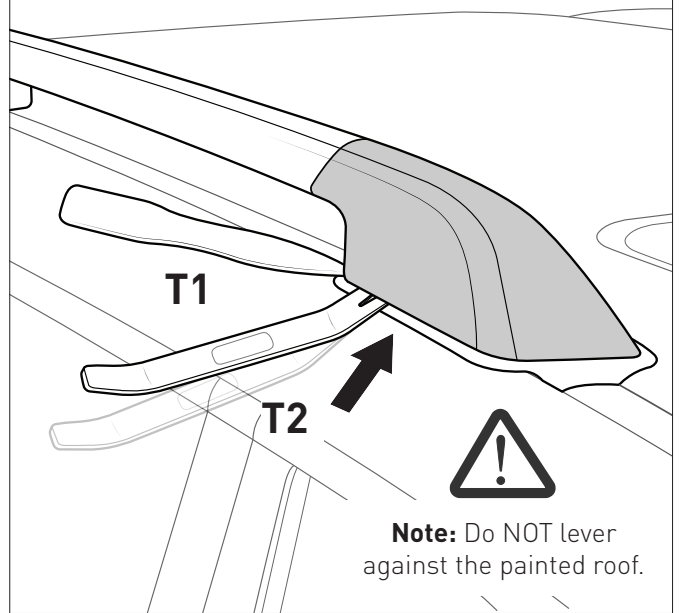

1c Slide the second trim tool **T2**, with a light rocking motion, towards the end of the rail until the internal clips release.

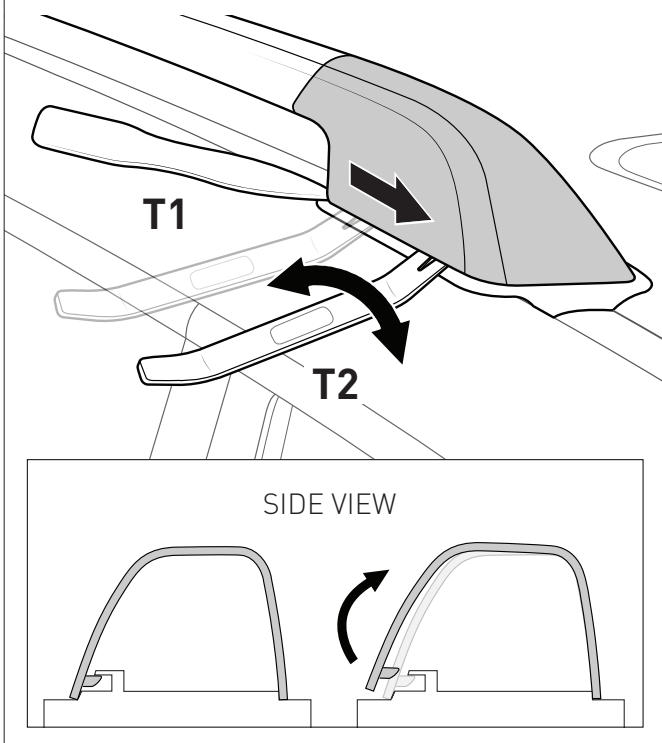

1d Roll and lift end cap to remove.

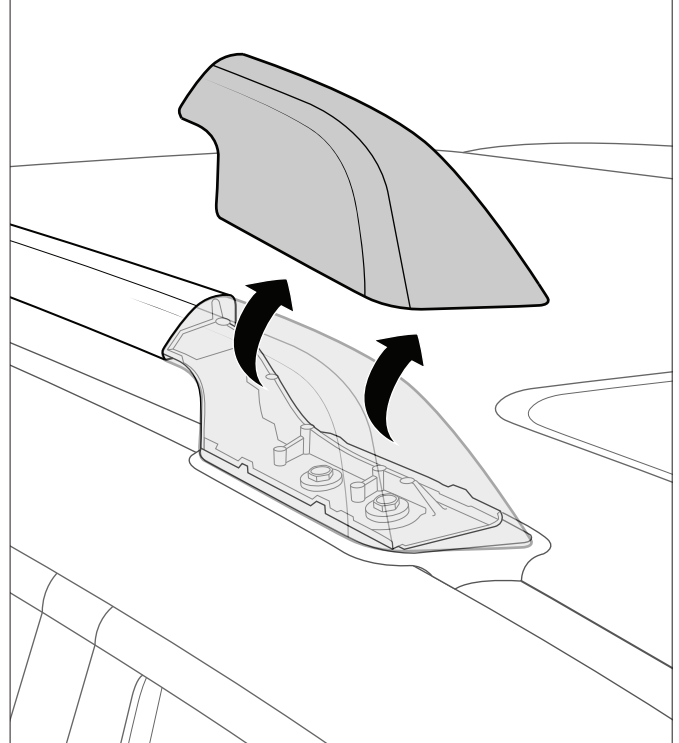

RTL5 Backbone Instructions

2 Remove centre rail cap.

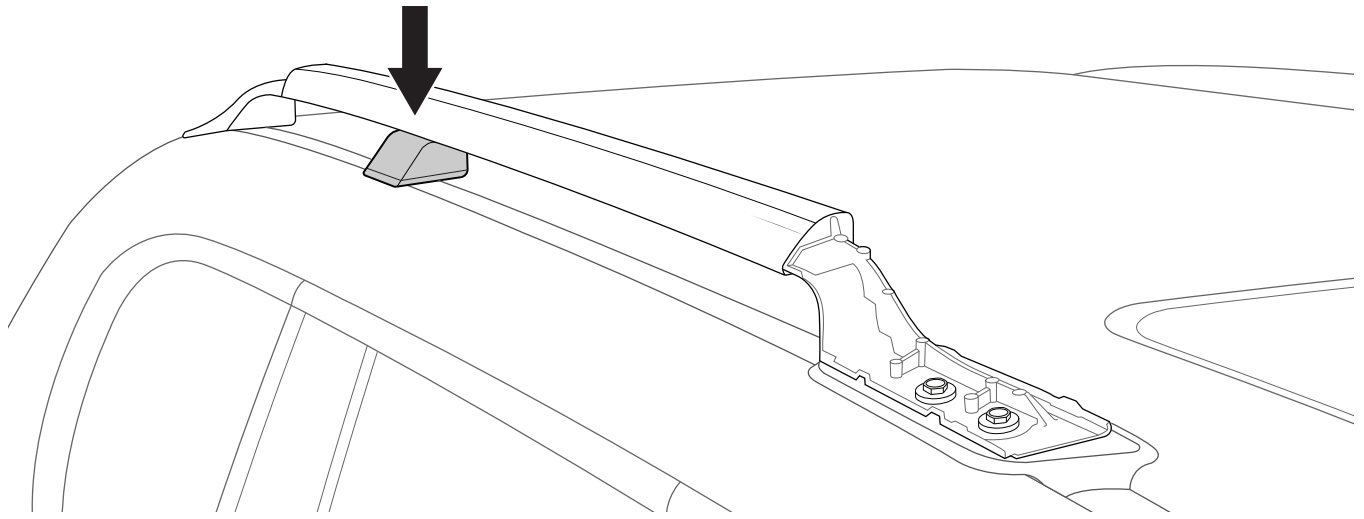

2a Slide the pointed trim tool into the gap between the plastic cover and the rail brace to release the internal clip.

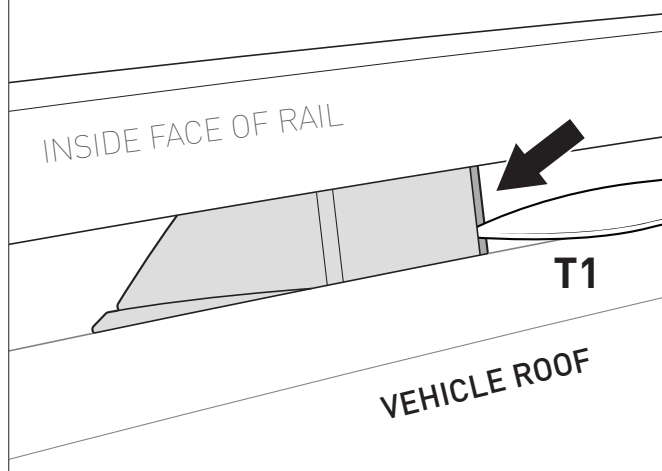

2b Swing the cover around and remove.

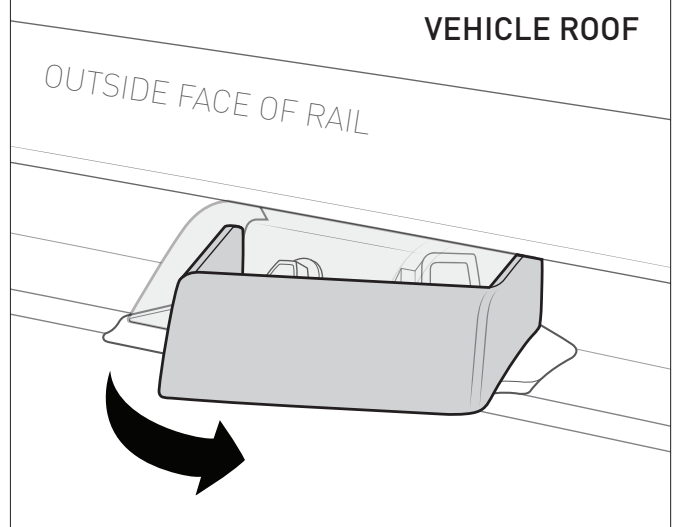

3 Break both bolts loose, incrementally turning each a half turn at a time, until they are both loose enough to remove by hand.

Repeat removal for rear rail bolts.

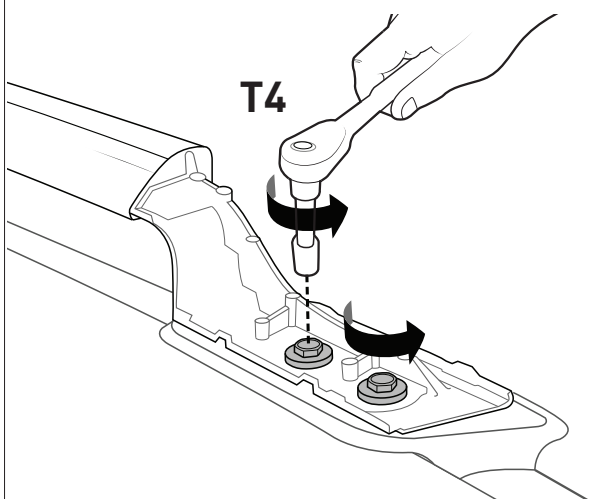

Ensure both bolts are loose before removing either bolt completely.

Failure to do so may lead to the internal threaded roof plate being dislodged.

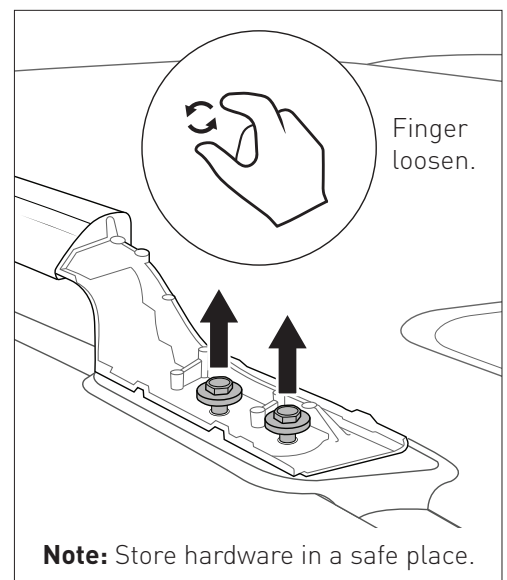

RTL B5 Backbone Instructions

- 4** Remove centre rail factory hardware.

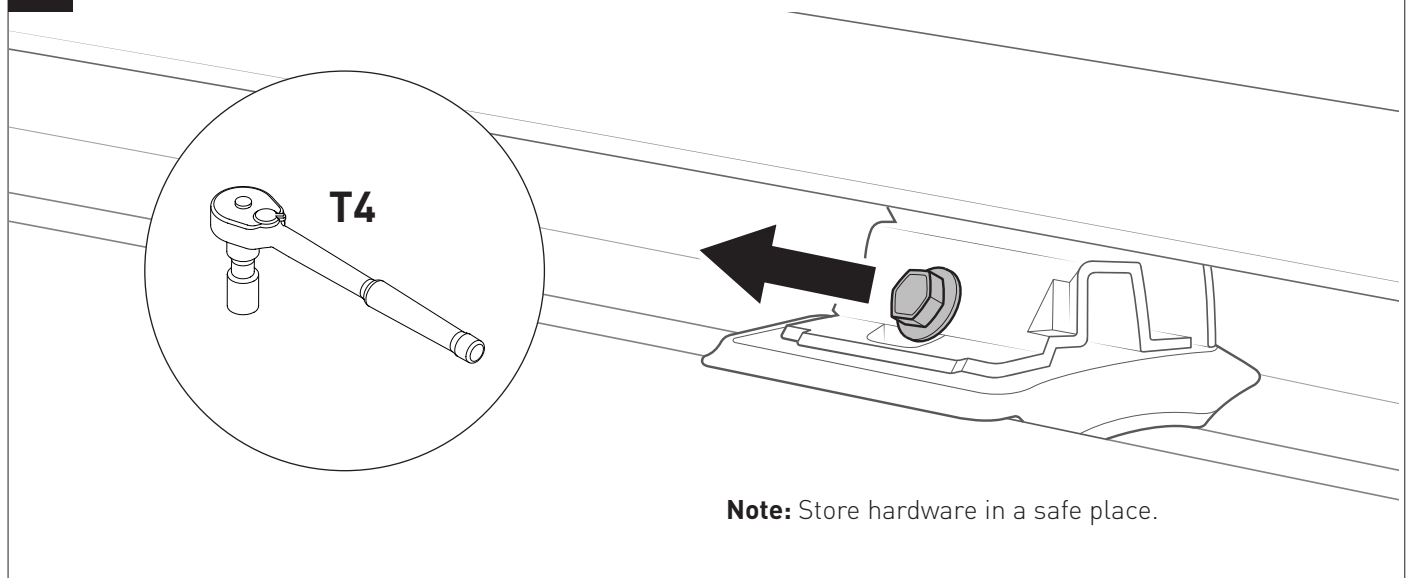

- 5** Remove rail by lifting vertically.

Note: Store in a safe place.

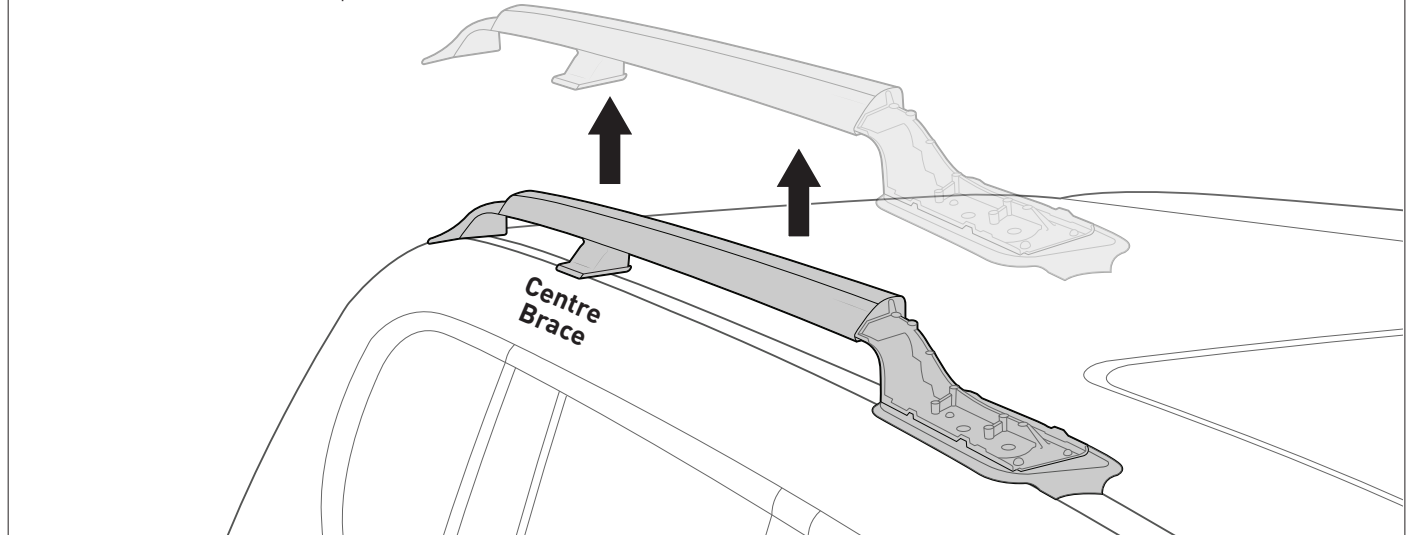

- 6** Remove hardware from the centre brace, turning each bolt incrementally half a turn until loose.

Note: Store hardware in a safe place.

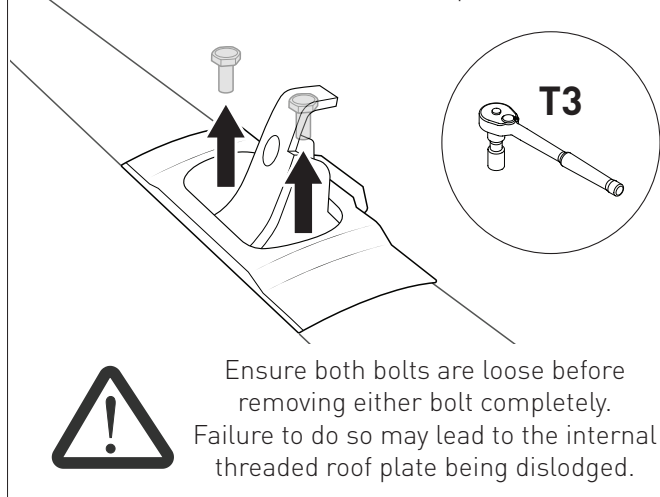

- 7** Remove centre brace and cover by lifting vertically.

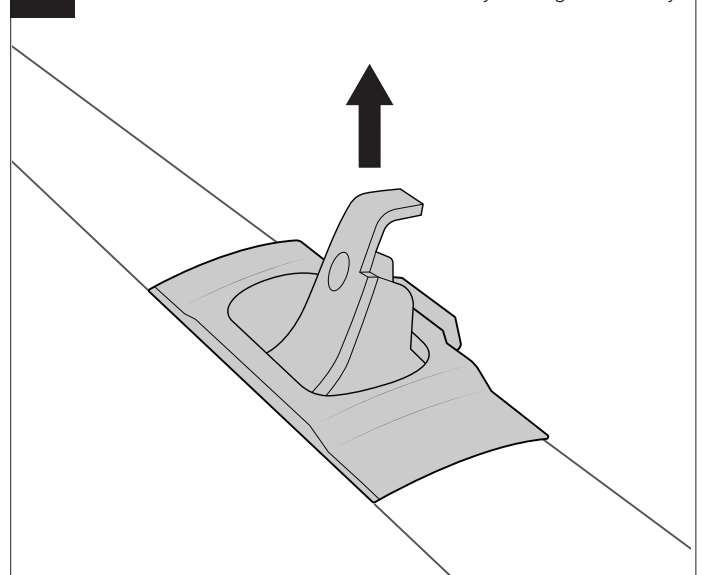

RTL5 Backbone Instructions

- 8** At the **front** of the vehicle, remove the plastic cover by pushing in the direction of the arrow and lifting.

Keep plastic cover for reattachment at Step **11**

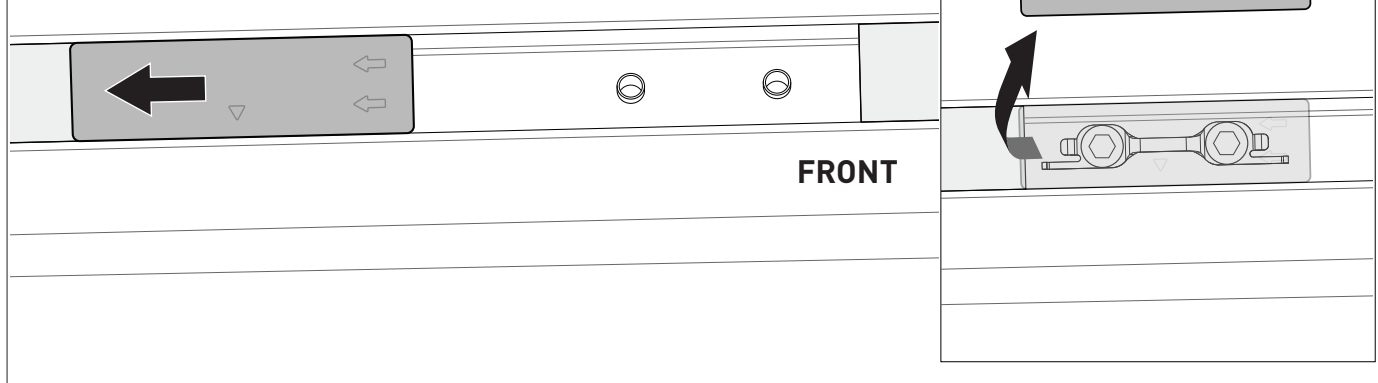

- 9** Incrementally loosen both bolts half a turn at a time (similar to Step **3**).

Remove hardware and hook, and move them to the **front-most** mounting point (refer to Step **10**).

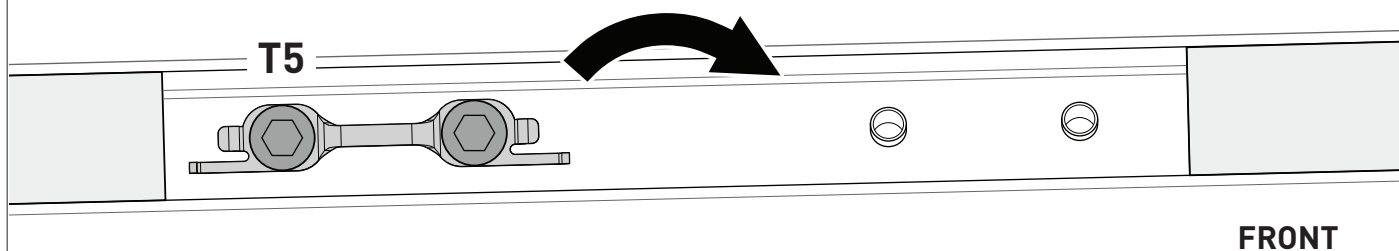

Ensure both bolts are loose before removing either bolt completely. Failure to do so may lead to the internal threaded roof plate being dislodged.

- 10** Move the hook and hardware from Step **9** to the **front-most** mounting point. Insert both bolts simultaneously and gently into the internal roof plate and finger tighten. Once both bolts are threaded into the internal roof plate, use **T5** to tighten.

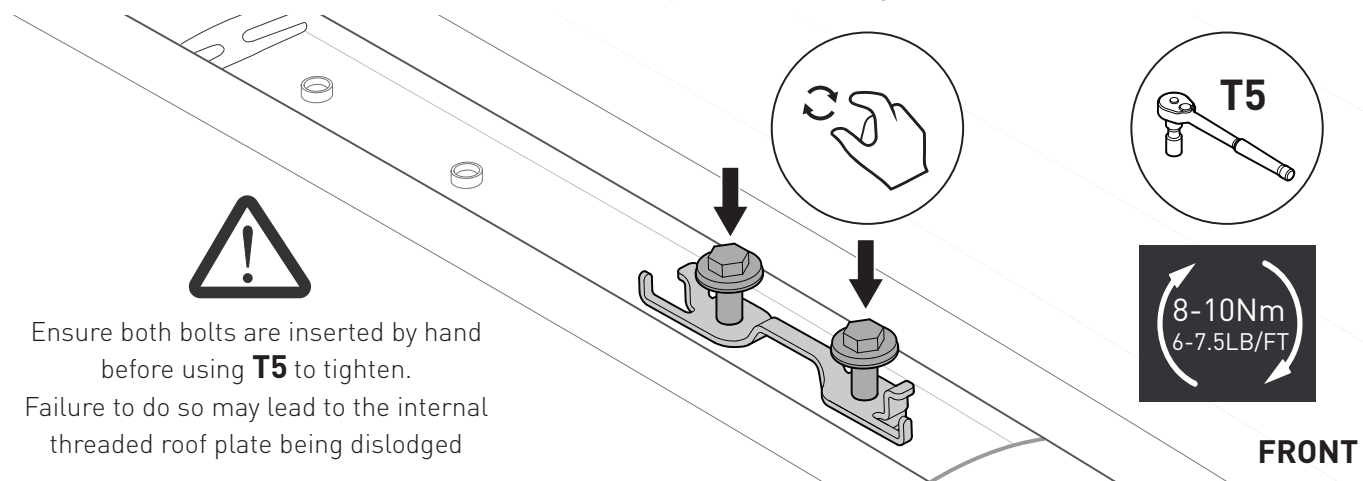

Ensure both bolts are inserted by hand before using **T5** to tighten. Failure to do so may lead to the internal threaded roof plate being dislodged

RTL B5 Backbone Instructions

- 11** Relocate plastic cover onto the hook in its new position.

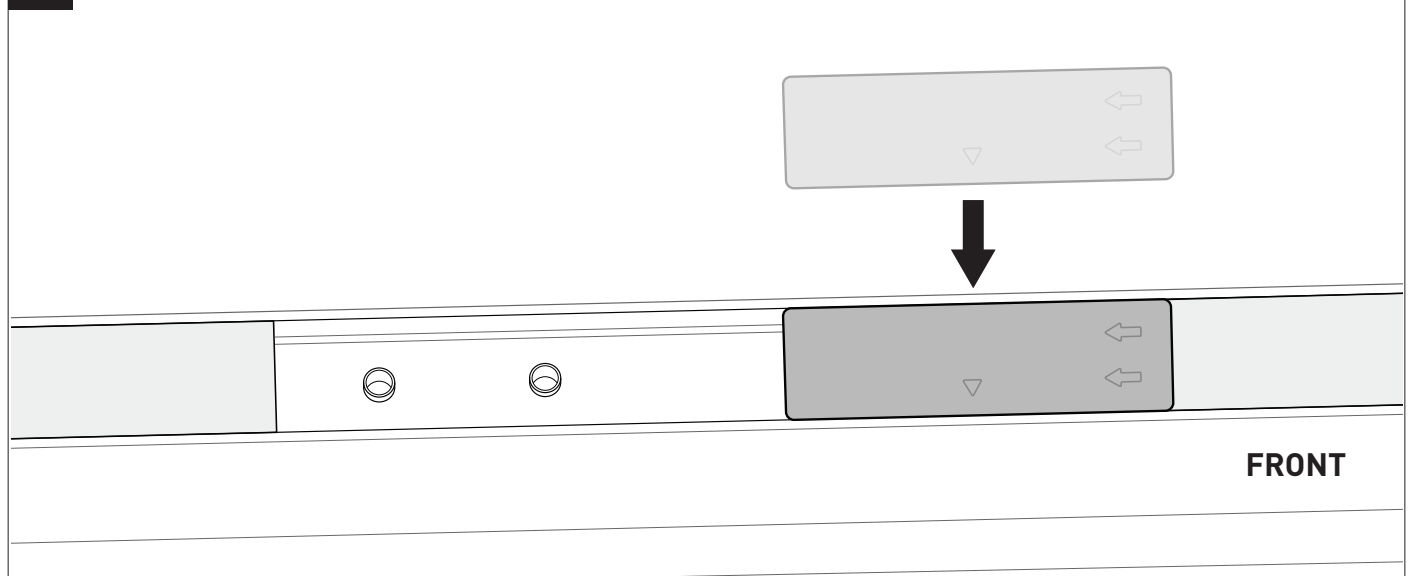

BARE ROOF MOUNTING POINTS (For Factory Rail Variant, skip to Step 14)

- 12** Remove mounting point covers (three per side).

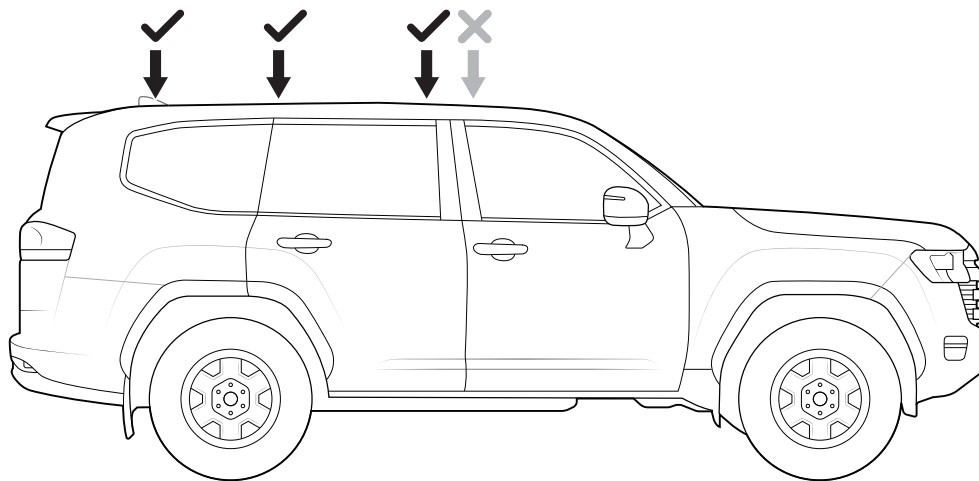

- 12a** Lift end while pushing in the direction of the arrow.

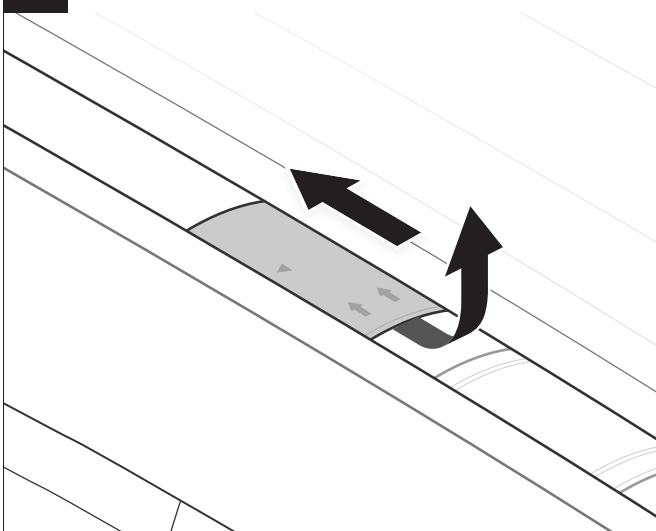

- 12b** **Note:** Store covers in a safe place.

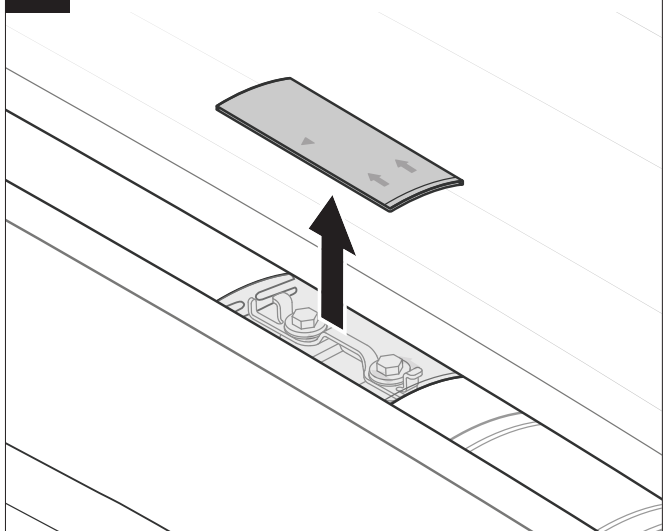

RTL B5 Backbone Instructions

13 Remove factory bolts and hooks from selected mounting points. **Note:** Store hooks & hardware in a safe place.

13a Break both bolts loose, incrementally turning each a half turn at a time, until they are both loose enough to remove by hand.

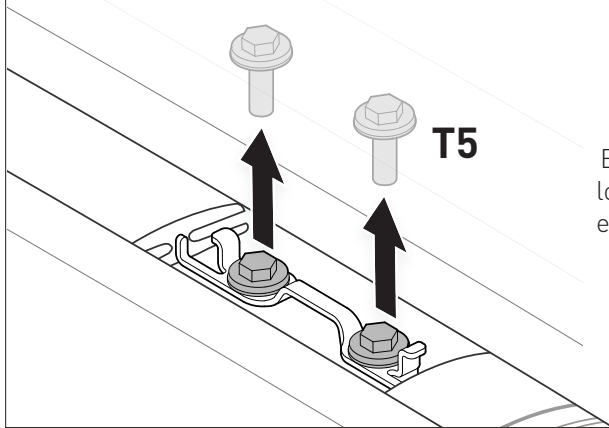

Ensure both bolts are loose before removing either bolt completely.

Failure to do so may lead to the internal threaded roof plate being dislodged.

13b

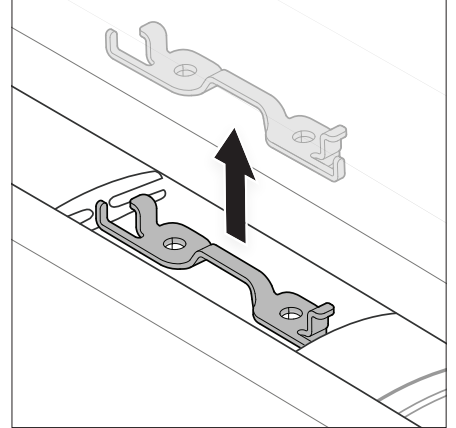

14 Clean the exposed ditch areas.

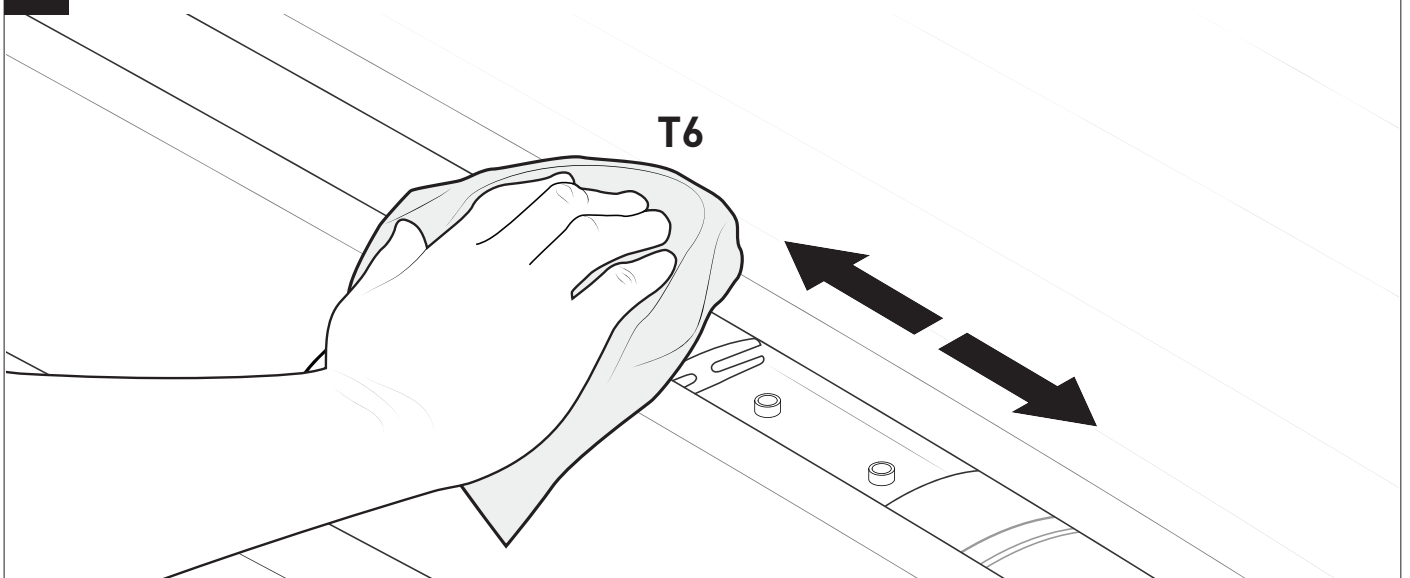

15 Assemble mounting blocks (3 per side) with supplied flanged bolts. Insert both bolts simultaneously and gently into the internal roof plate and finger tighten.

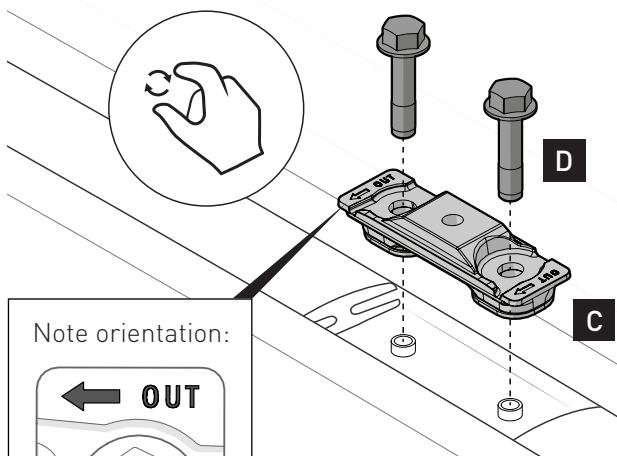

Ensure both bolts are inserted by hand before using **T5** to tighten.

Failure to do so may lead to the internal threaded roof plate being dislodged

Once both bolts are threaded into the internal roof plate use **T5** to tighten

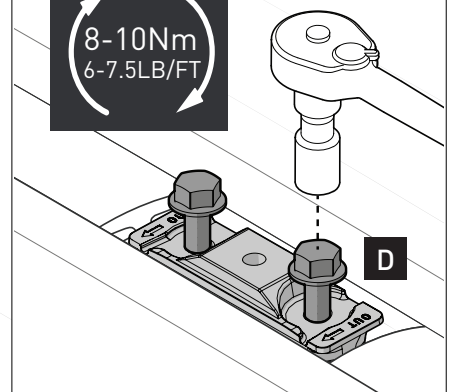

16

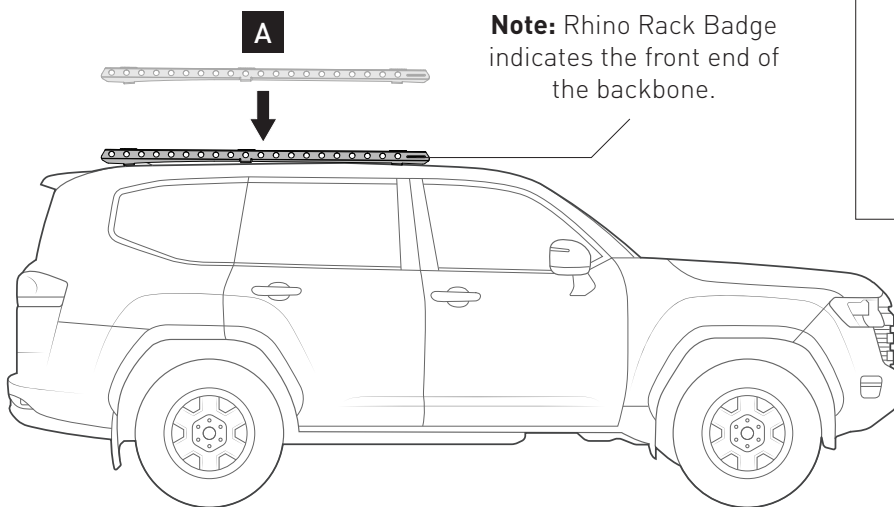

Note: Rhino Rack Badge indicates the front end of the backbone.

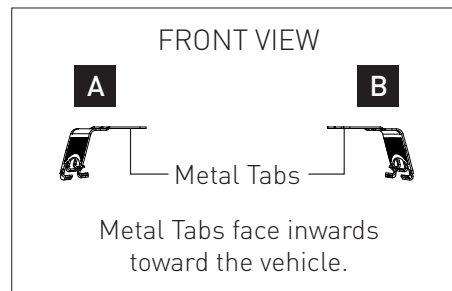

17

Assemble hardware onto the centre leg and start screw.
Do not fully tighten screw.

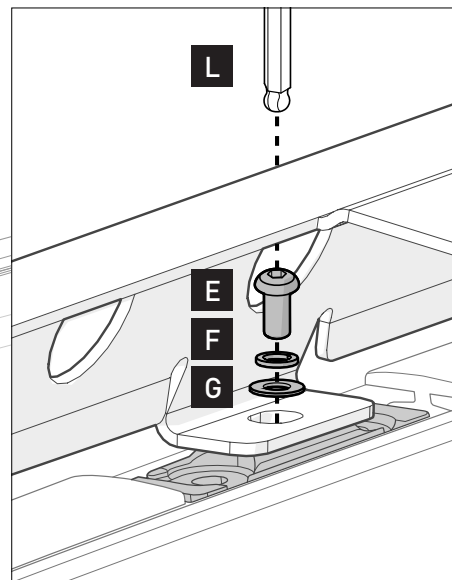
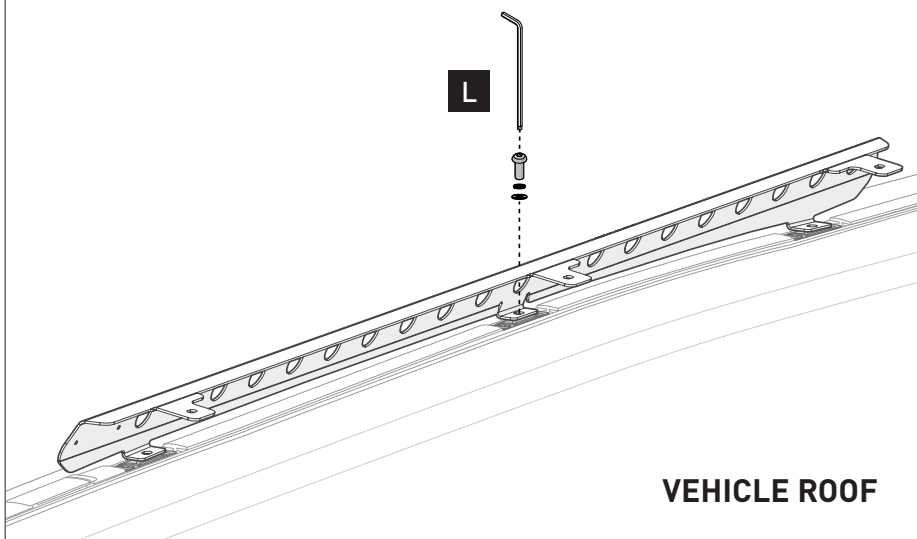

18

Assemble hardware onto the front and rear leg and start both screws.
 Incrementally tighten hardware for all three leg locations:
front, centre and rear.

Note: Ensure backbones are securely positioned and fastened before attaching Pioneer Tray.

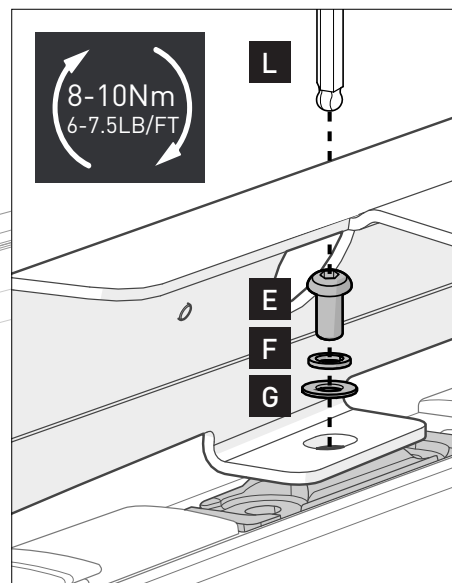
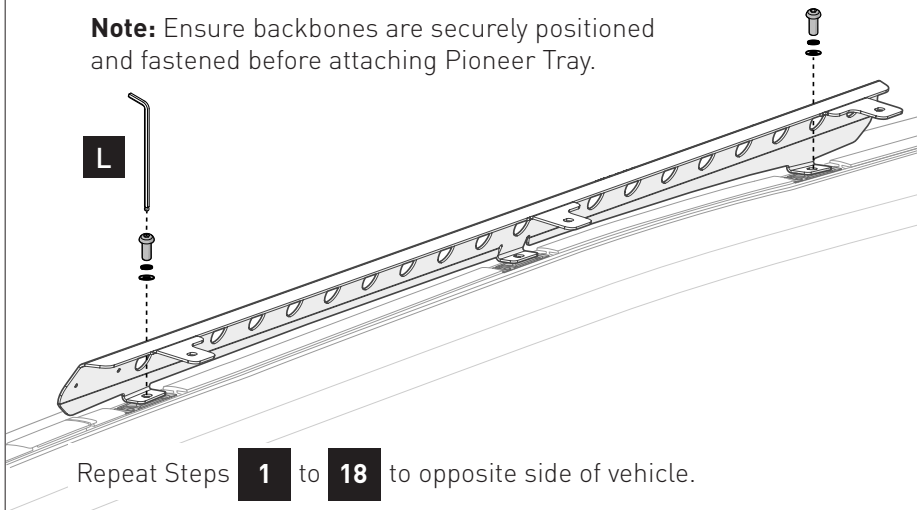

19 PLATFORM INSTALLATION



rhinorack.com/roof

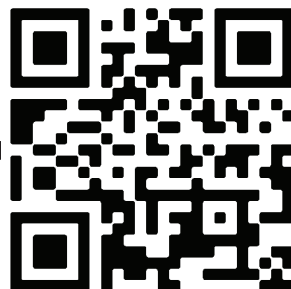

EXAMPLE ONLY

RHINO-RACK | PIONEER VEHICLE FITTING INFORMATION

VEHICLE	YEAR	MAKE	MODEL	CONNECTOR	ROOF ACCESSORY
2015-2017	2015	2016	2017	2018	2019

VEHICLE WEIGHT
 96 Kg + 24 Kg = 120 Kg
 212 lbs + 53 lbs = 265 lbs

VEHICLE MANUFACTURER'S ROOF LOAD LIMIT

UNDERBAR SPACING

BAR	A	B	C	D	E	F	G	H
UNDERBAR	10	10	10	10	10	10	10	10

View Fitting Chart

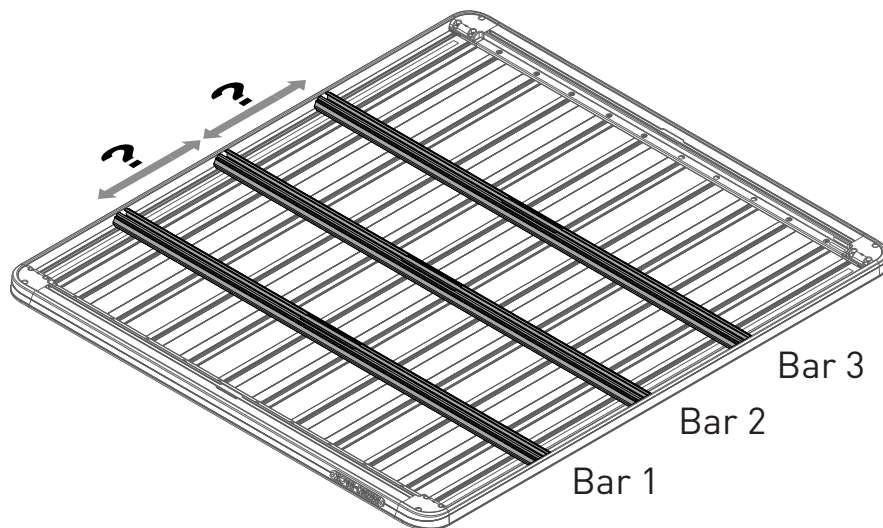

20 For 5XXXX Series Platform

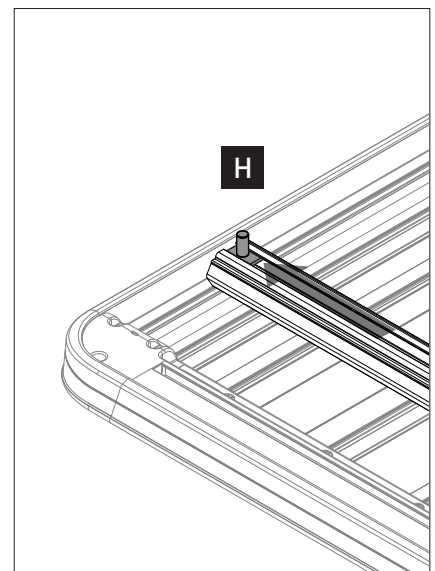
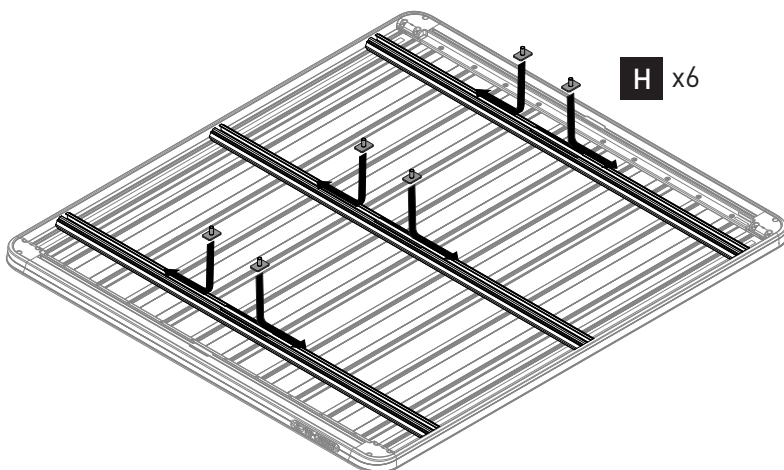

21 For 5XXXX Series Platform

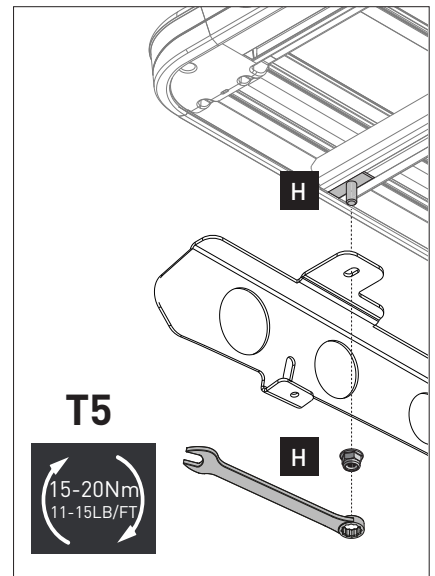
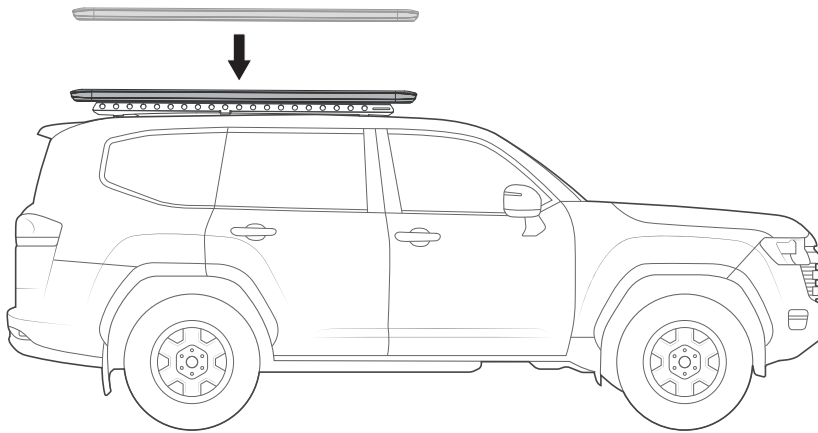

22 For 4XXXX Series Platform

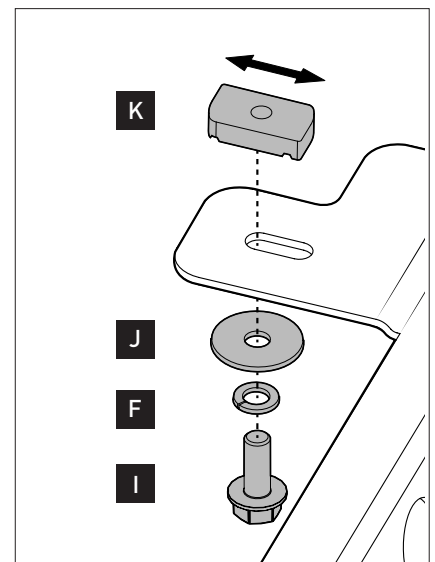
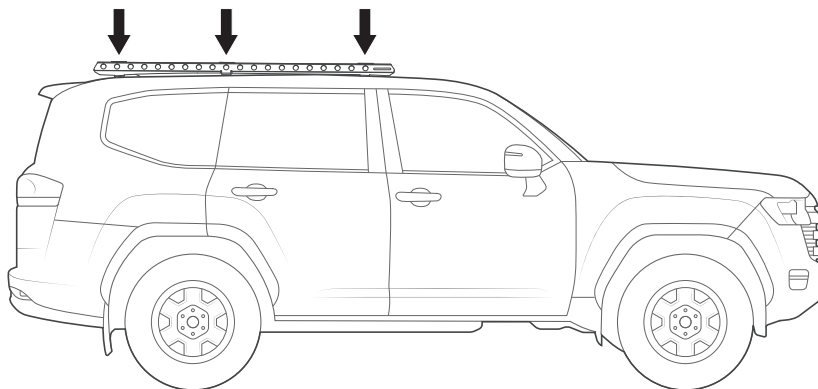

23 For 4XXXX Series Platform

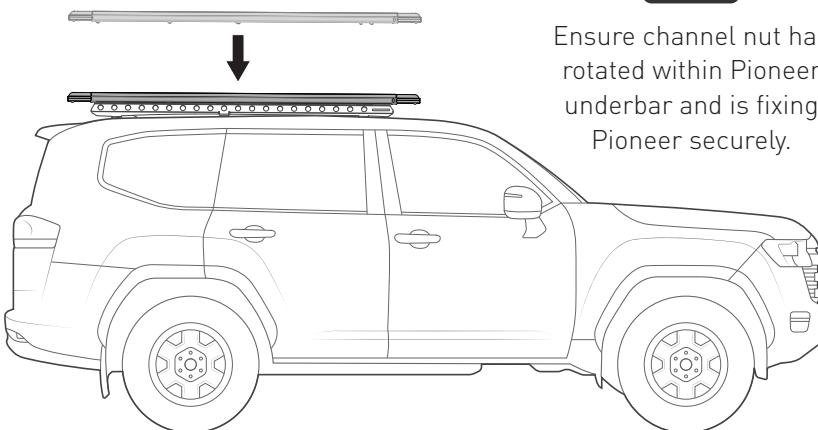

Ensure channel nut has rotated within Pioneer underbar and is fixing Pioneer securely.

