

BACKBONE

Jeep Wrangler JK 2dr Hard Top 2007 On

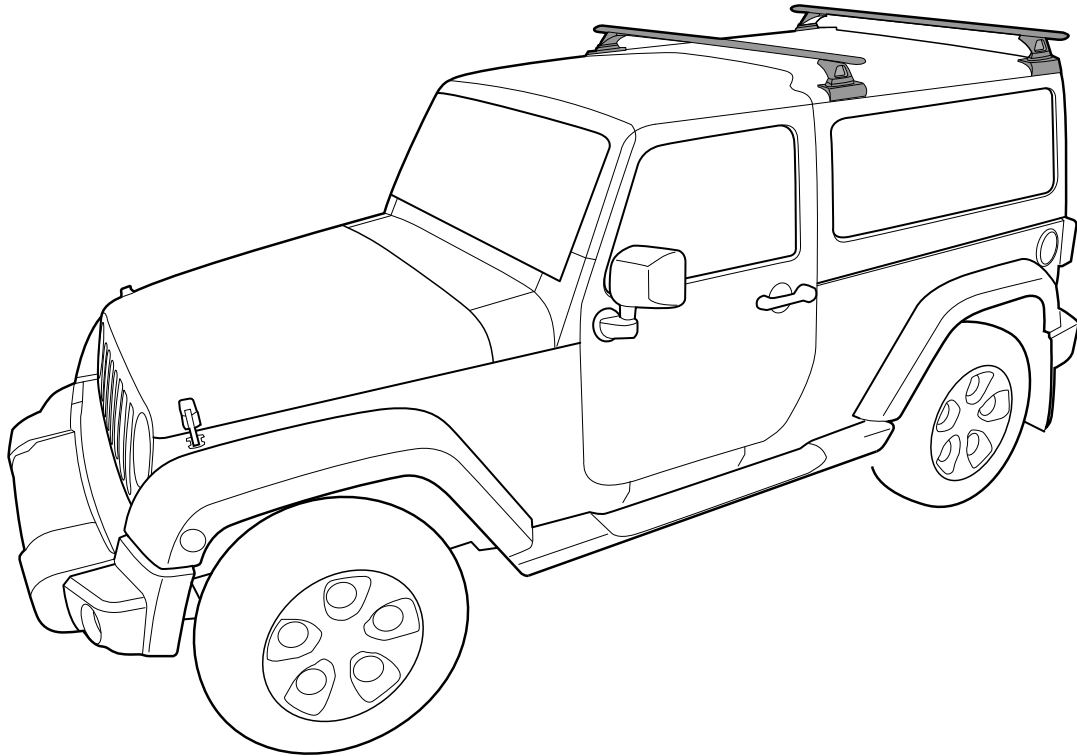

Important Information

Max: 100kg (220lbs) - Two Crossbars.

Time: 2 Hours.

Read through instructions before installation. If you are unsure or have any questions, refer to the dealer or place of purchase.

Recommendations:

It is essential that all bolt connections be checked after driving a short distance when you first install your crossbars. Bolt connections should be checked again at regular intervals (probably once a week is enough, depending on road conditions, usage, loads and distances travelled). You should also check the crossbars each time they are refitted. Make sure to fasten your load securely. Please ensure that all loads are evenly distributed and that the centre of gravity is kept as low as possible. Use non stretch ropes.

Please remove crossbars when putting vehicle through an automatic car wash.

Load Ratings:

Maximum permissible load is 100kg (220lbs) for two crossbars including the weight of the crossbars, 5kg (11lbs). When crossbars are to be used in off-road conditions, please build a safety factor of 1.5 into this load limit for off-road use, two crossbars = **66kg (145lbs)**. Although the crossbars are tested and approved to AS1235-2000, Off road conditions can be much more rigorous. However, increasing the number of crossbars does not increase the vehicles maximum permissible roof loading.

Note for Dealers and Fitters: This is a two person installation. The removal of the hard top requires assistance. It is your responsibility to ensure instructions are given to the end user or client.

Rhino-Rack
3 Pike Street, Rydalmere,
NSW 2116, Australia.
(Ph) (02) 9638 4744
(Fax) (02) 9638 4822

Document No: R438
Prepared By: Kayle Everett
Authorised By: Chris Murty

Issue No: 01
Issue Date: 16/10/2014

These instructions remain the property of Rhino-Rack Australia Pty. Ltd. and may not be used or changed for any other purpose than intended.

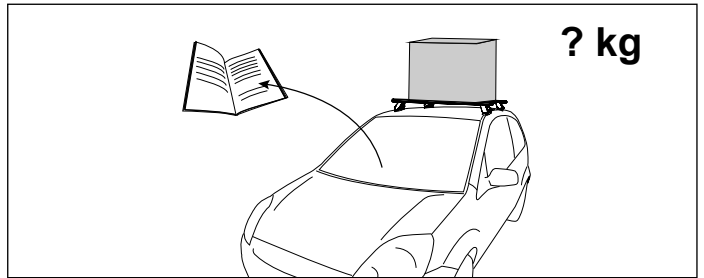
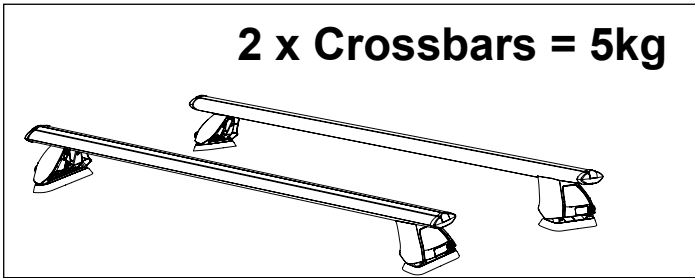
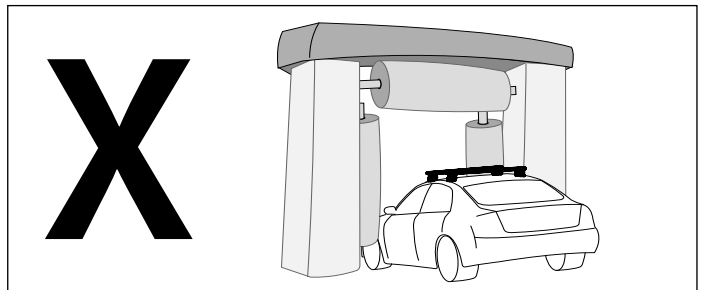
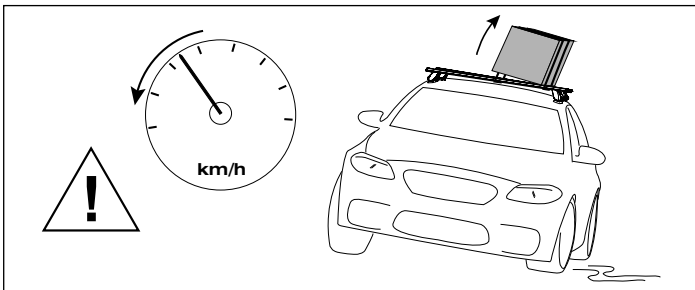
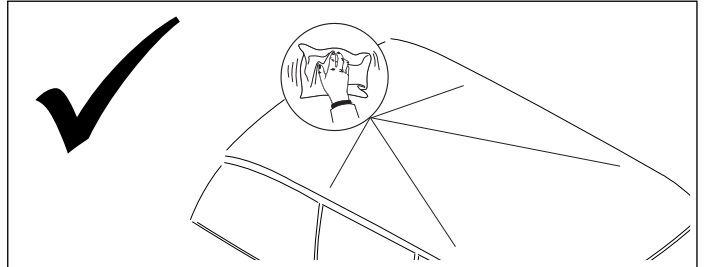
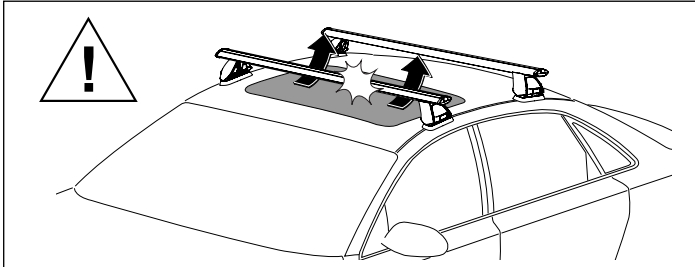
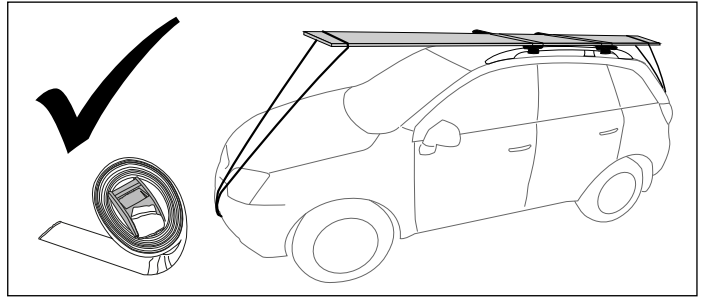
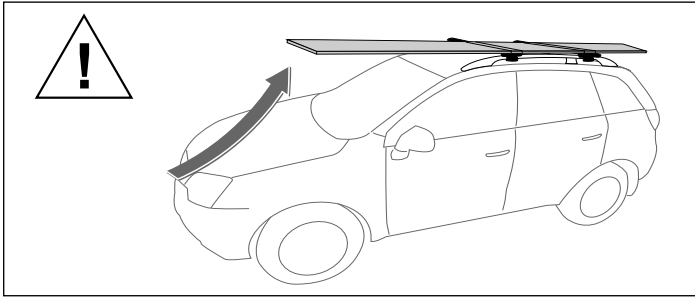

When these roof racks are to be used on a vehicle that is driven off sealed roads the maximum load rating must be divided by 1.5. Remember to subtract the weight of the roof racks to determine your maximum permissible load capacity.

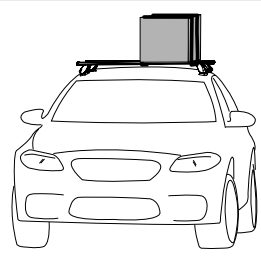

2 bars 100kg (220lbs) load rating (Urban road) = 2 bars 66kg (145lbs) load rating (Off road)

Load rating not taking into account crossbar weight - 5kg

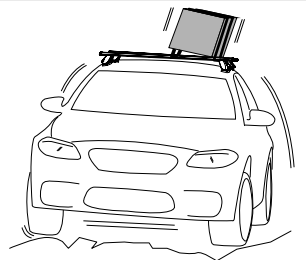

WARNING! Important Load Carrying Instructions
With utility vehicles, the cabin and the canopy move independently. Roof racks and vehicle can be damaged if the item transported is rigidly fixed at points on both the cabin and canopy. Instead, rigidly fix to either the cabin roof racks or the canopy roof racks.

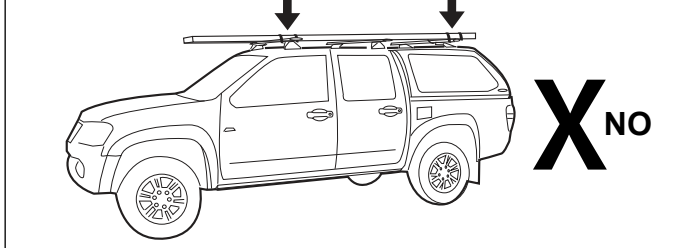
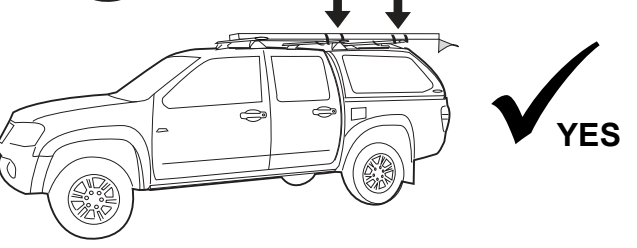
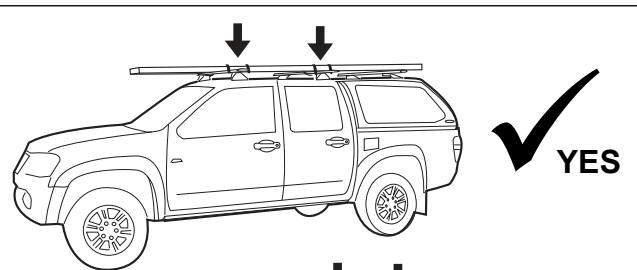



Parts List

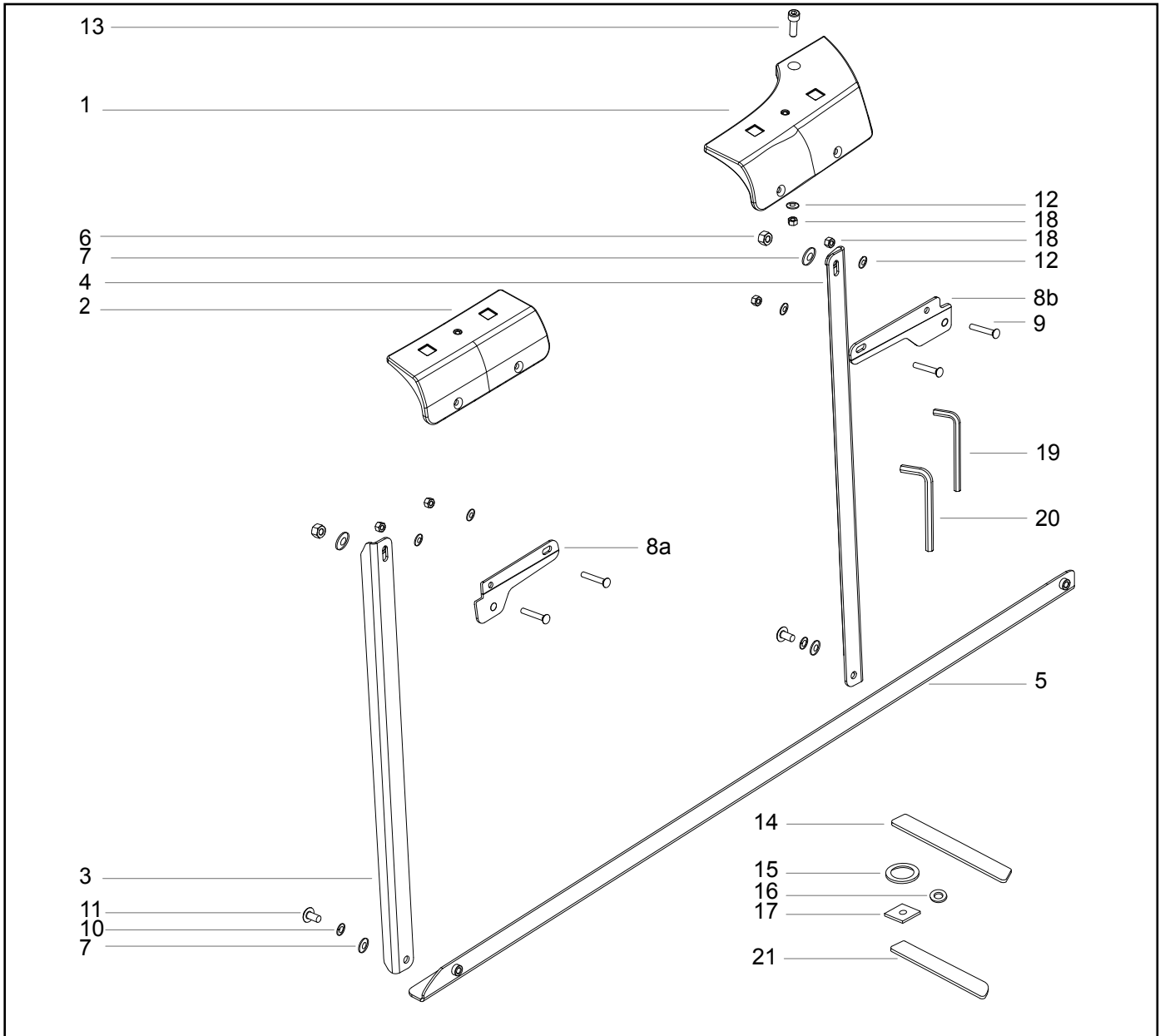

Item	Component Name	Qty R	Qty L	Part No.
1	Rear Bracket	1	1	CA1274
2	Middle Bracket		2	CA1275
3	Internal Support Vertical Front		2	CA1358
4	Internal Support Vertical Rear		2	CA1280
5	Internal Support Base	1	1	CA1324

Item	Component Name	Qty	Part No.
6	M8 Nyloc Nut Black	4	N043
7	M8 Flat Washer Black	8	CA1068
8a	Bracket Fixture Plate Front	2	CA1325
8b	Bracket Fixture Plate Rear	2	CA1282
9	M6 x 40 Socket HD Bolt Black	8	B211
10	M8 Spring Washer Black	4	W019-Blk
11	M8x20 Hex Setscrew Black	4	B020-Blk
12	M6 Flat Washer Black	10	W054-Blk
13	M6 x 30 Socket HD with O-Ring	2	B210
14	Middle Bracket Foam	2	CA1284
15	Bracket O Foam L	2	CA1285
16	Bracket O Foam S	4	CA1286
17	Bracket Foam Square	2	CA1287
18	M6 Nyloc Nut Blk	10	N069
19	4mm Allen Key	1	H001
20	5mm Allen Key	1	H002
21	End Bracket Rear Foam	2	-
22	Instructions	1	R438

Tools Required:

- 10mm Spanner
- 13mm Spanner
- Drill
- 3.0mm Drill Bit
- 6.5mm Drill Bit
- 5mm Allen Key (supplied)
- Support Stands
- 6-18mm Step Drill
- Tape Measure
- Marker Pen
- 4mm Allen Key (supplied)



1 Remove the Hard Top (as per manufacturer's instruction) and place onto a stable, safe working area.

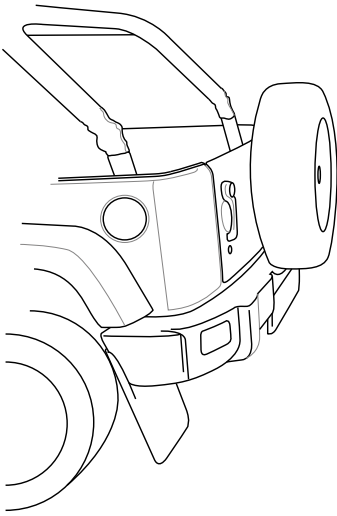

Hardware will have to be removed from inside Hard Top.

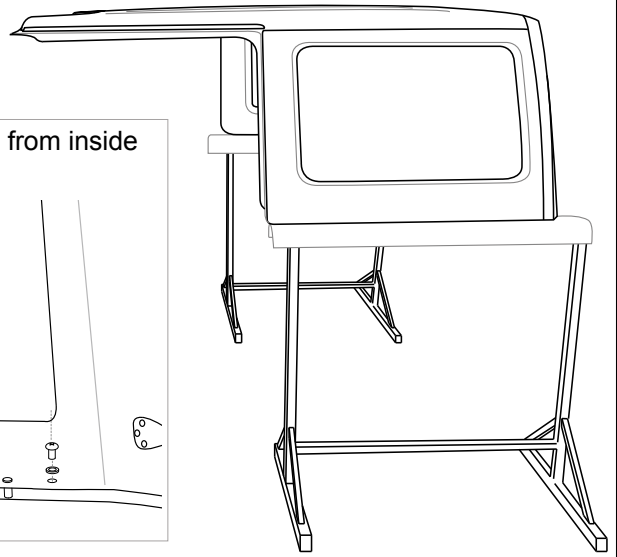
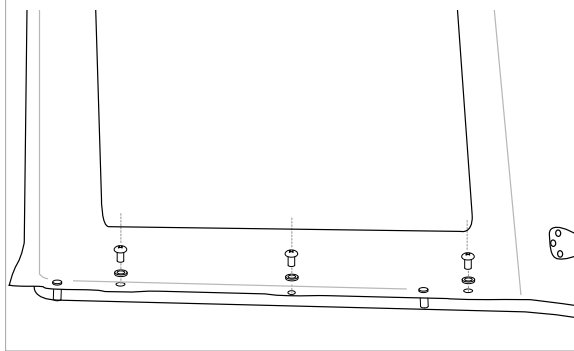

2a Assemble the Support Struts as shown. Finger tighten. Check part ID to make left and right side supports.

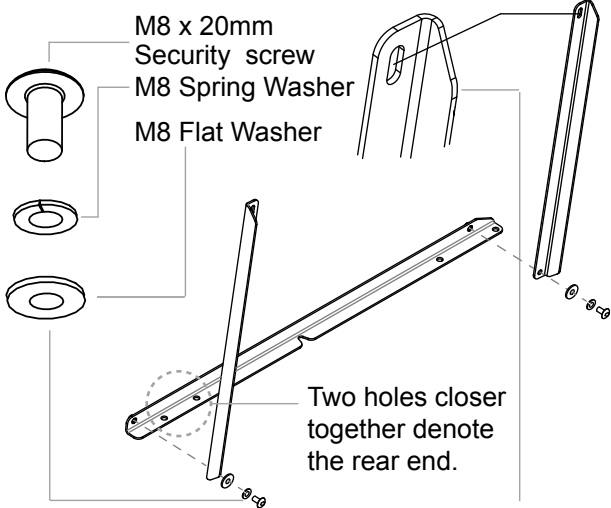

2b Attach item 8a,b to the arms as shown, using an M8 washer and M8 an Nyloc nut. Finger tighten.

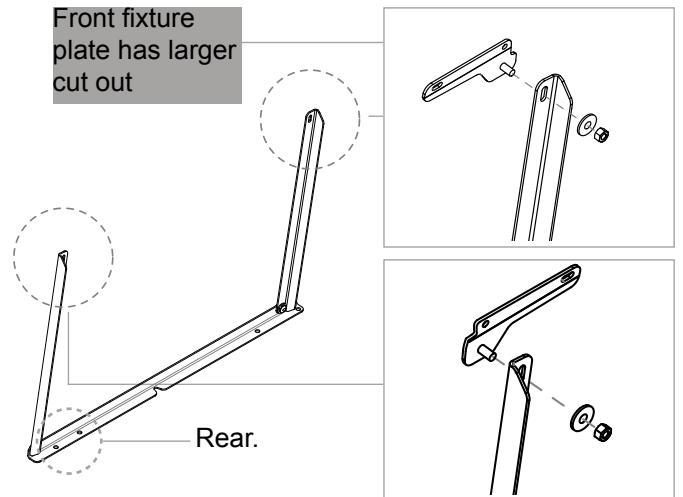

3 Repeat the process for for the opposing support strut.

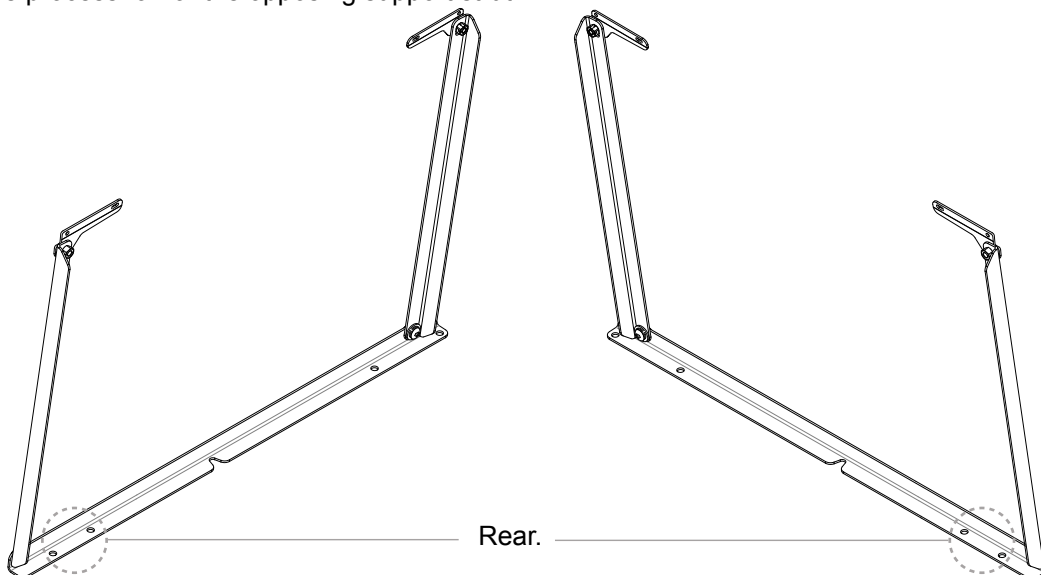



4 Align the REAR bracket with the REAR of the Hard Top. Line the bracket flush with the contour of the Hard Top as show.

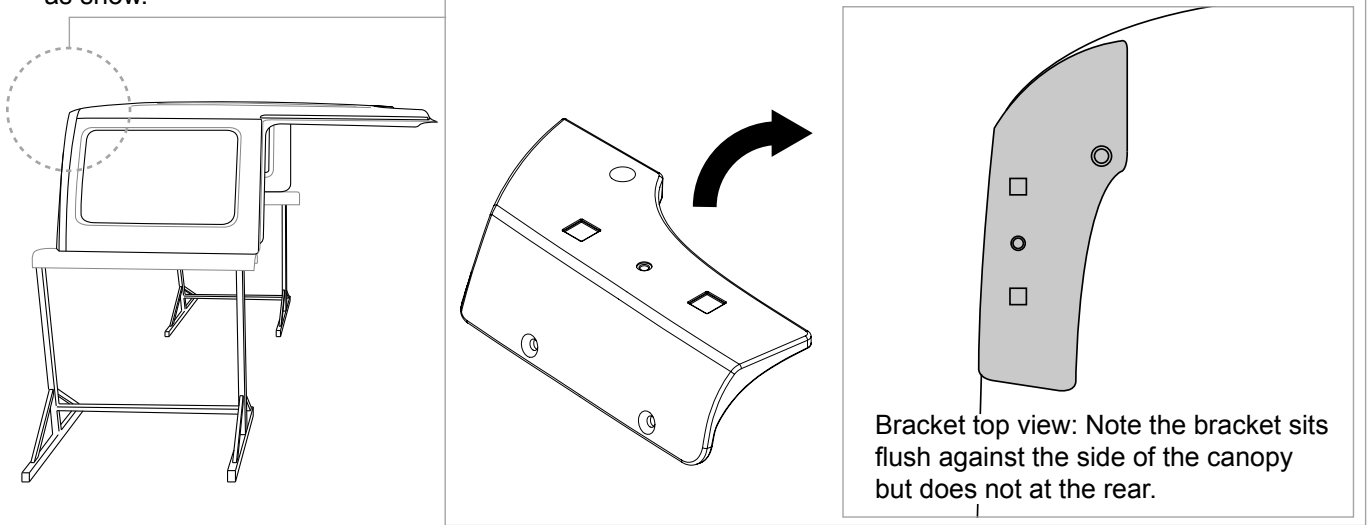

5 With bracket aligned, spot mark the bracket position as shown. It is important to be accurate when marking. Always mark the centre of the hole.

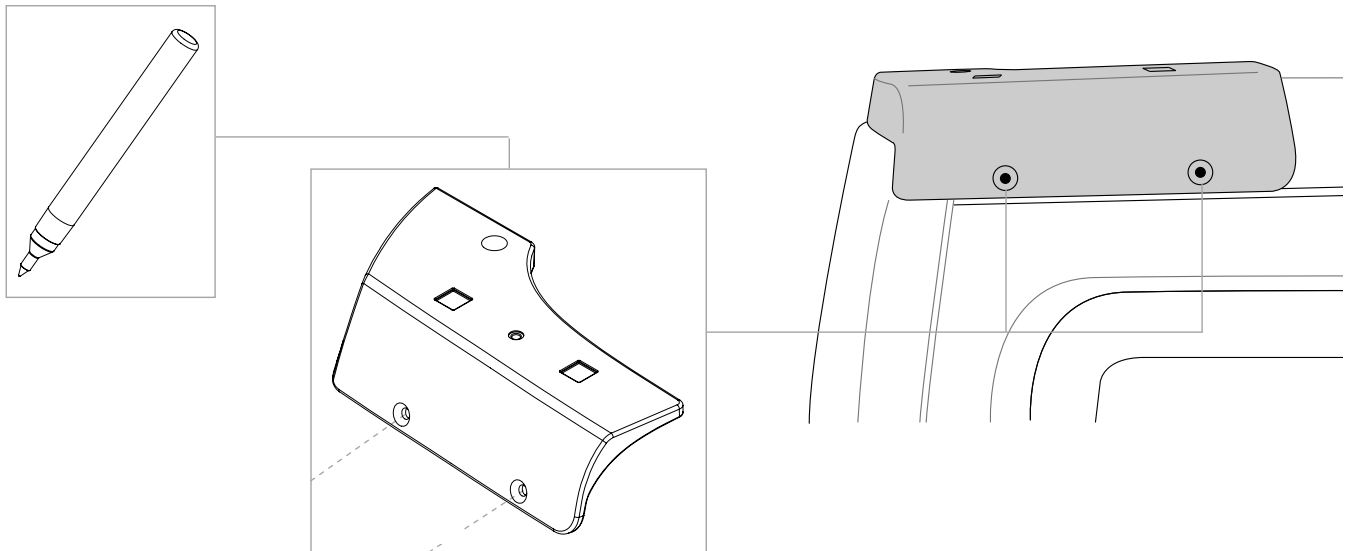

6 Align the Centre Bracket **against** the rain gutter on the Hard Top.

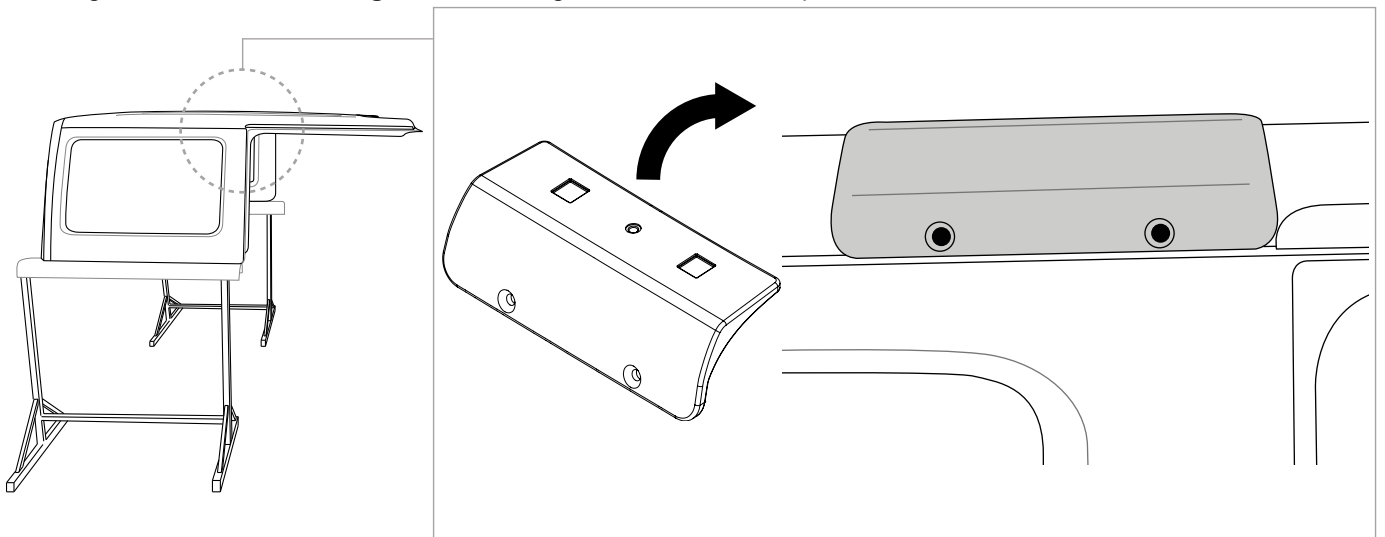



7 With the Centre Bracket aligned, spot mark the bracket position as shown.

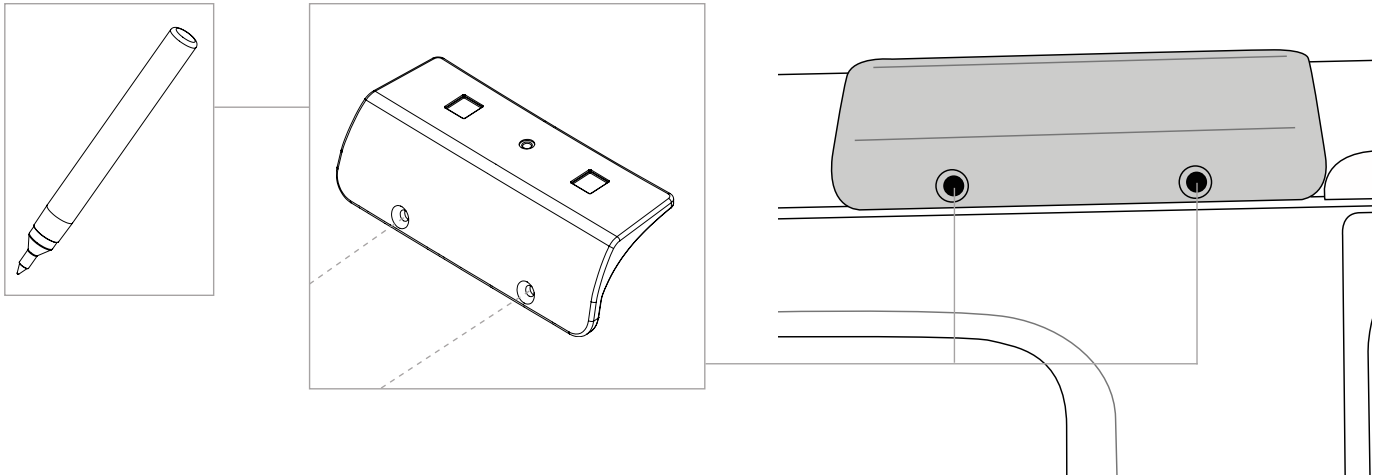

8 Using a 3mm (1/8") drill bit, spot drill **ALL** previously layed out. Angle drill when completing. Do not drill completely through roof.

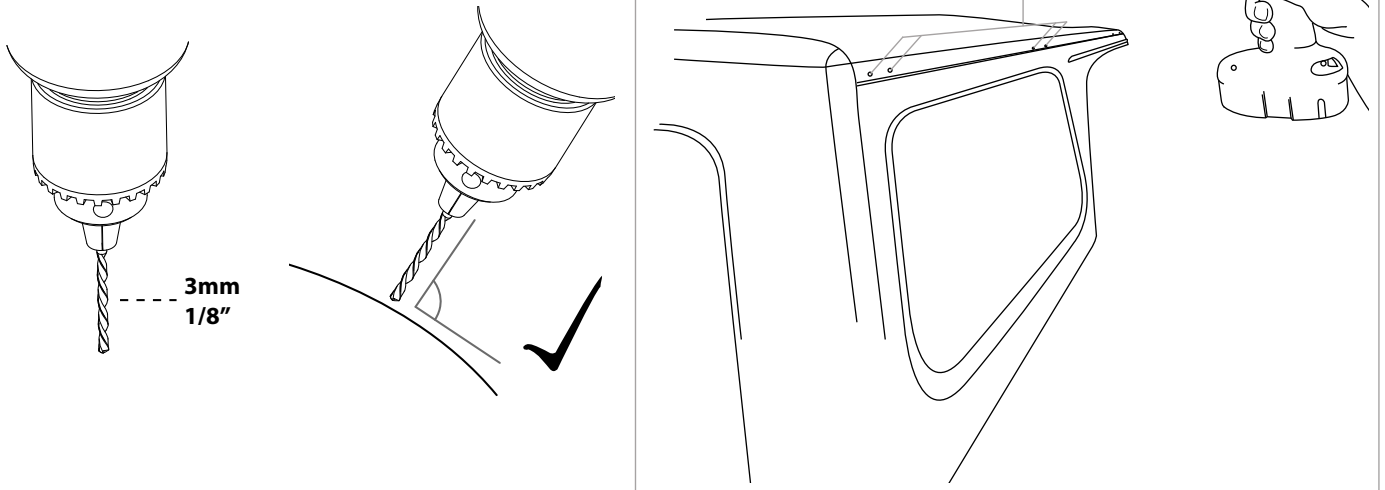

9 With relation to the Centre Bracket, take corresponding foam pads and remove the protective strip as shown. Fit to bracket.

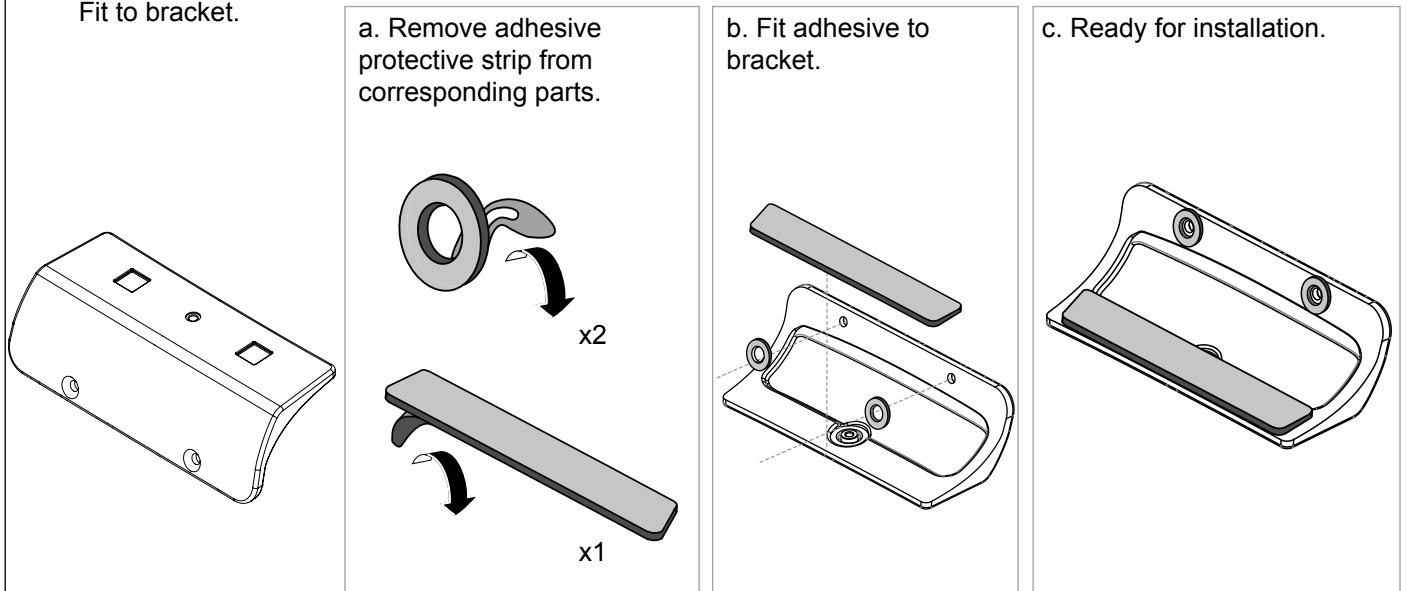



10 With relation to the Rear Bracket, take corresponding foam pads and remove the protective strip as shown. Fit to bracket.

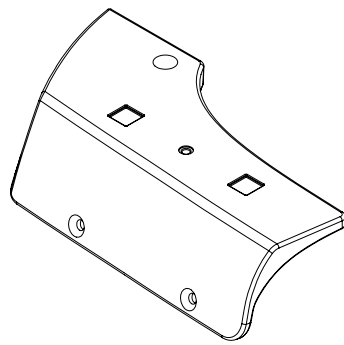

a. Remove adhesive protective strip from corresponding parts.

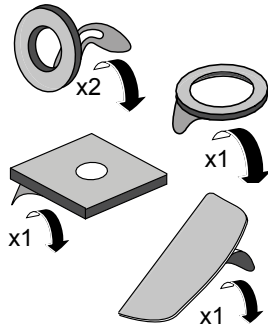

b. Fit adhesive to bracket.

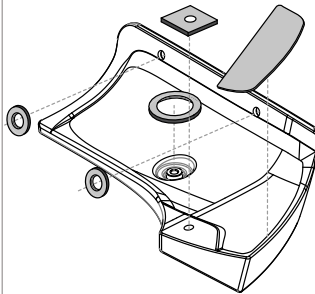

c. Ready for installation.

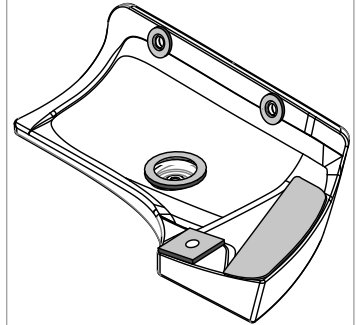

Note: Repeat the previous steps 4 to 10, for the opposing side of the Hard Top

11 With assistance to hold the Support Strut in place, set the assembly on the inside of the Hard Top as shown.

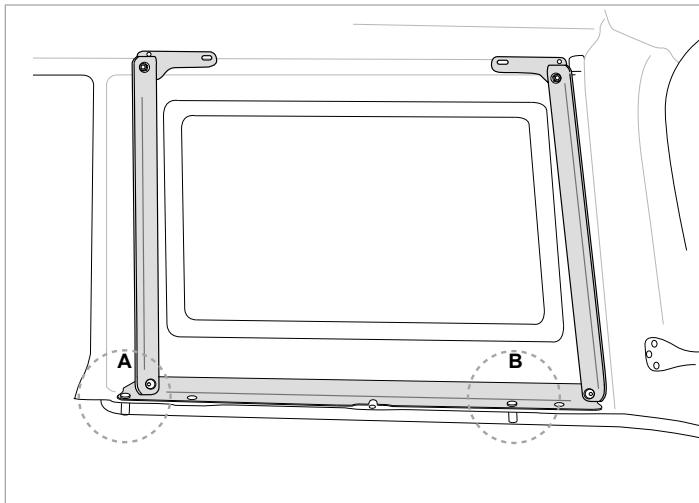

A. The Support Strut will slot onto the Hard Top studs as shown.

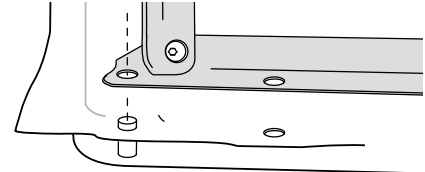

B. The Support Strut will slot onto the Hard Top studs as shown.

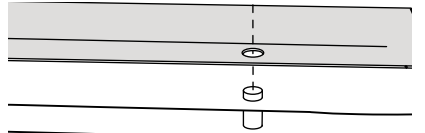

12 With assistance to hold the Support Strut in place, move to the outside of the Hard Top. Place the REAR Bracket in place. Insert M6 counter sunk screws, fastening from the inside with M6 black flat washers and M6 Nyloc nuts. Hold the nyloc nuts in place with a 10mm spanner. Tighten from the outside with a 4mm allen key. Repeat this process for the CENTRE Bracket.

1. Assemble as shown. Finger tighten to fix in place.

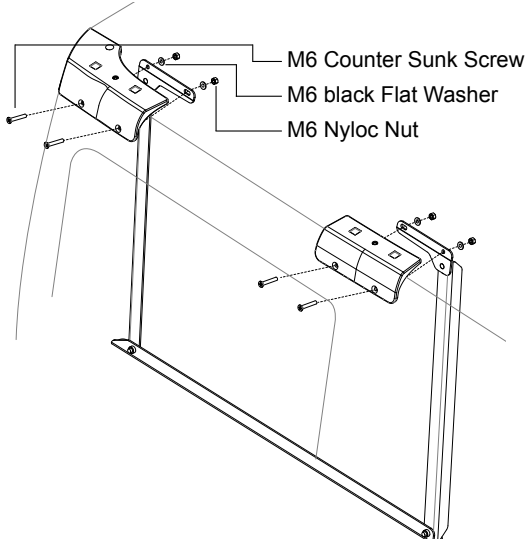

2. Hold Nyloc Nut with a spanner, allowing the bracket to be tightened from the outside.

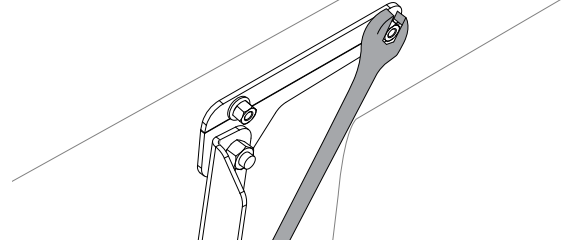

3. Fix with a 4mm Allen Key.

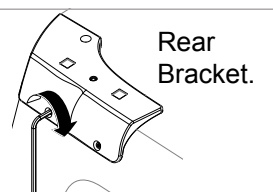

Rear Bracket.

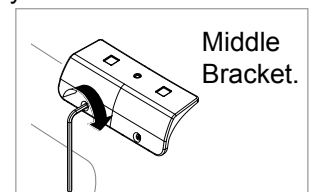

Middle Bracket.



- 13** With Rear Bracket now secure, drill out the top fixture point with a 6.5mm (1/4") bit. Use an M6 socket HD bolt with O'ring, an M6 flat washer and an M6 nyloc nut to fix the bracket.

View from inside Hard Top

Drill out fixture point.

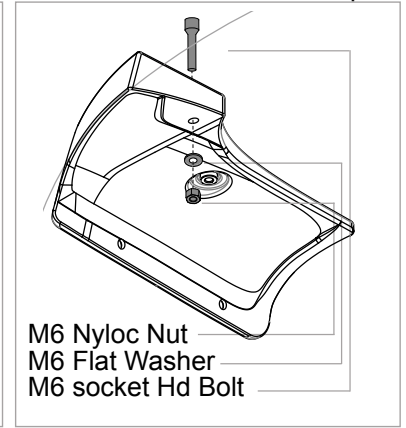
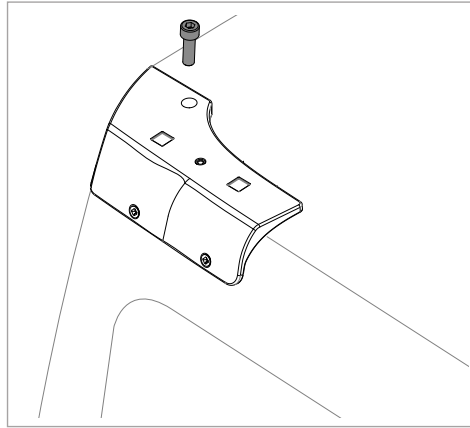
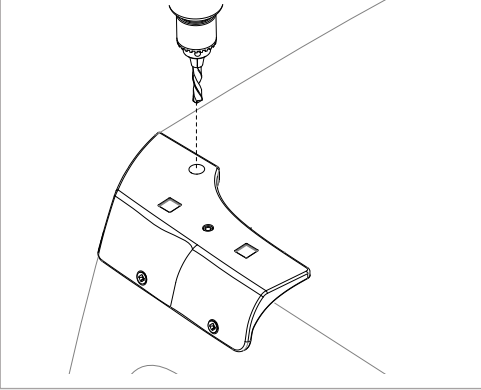

M6 Nyloc Nut
M6 Flat Washer
M6 socket Hd Bolt

- 14** Tighten supports with a 5mm allen key. Top of supports will require a 13mm spanner.

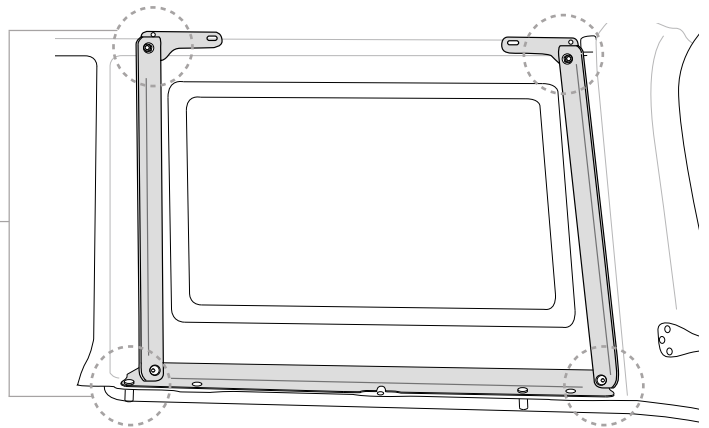
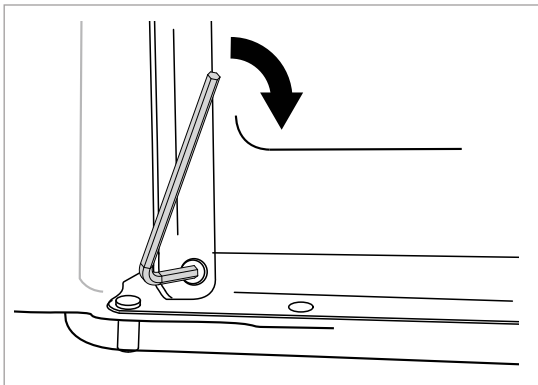

Note: Repeat previous steps 11-14 for the opposing side of the Hard Top

- 15** Place the Hard Top back onto the Jeep (refer to manufacturers instructions). Replace the hardware removed in step 1 on both sides of the inner Hard Top.

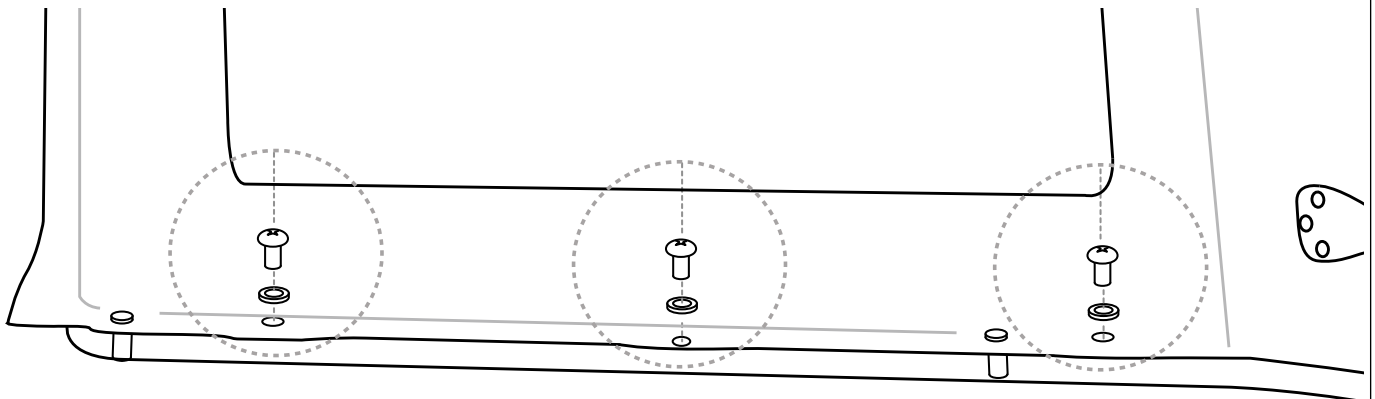



16 Attach Vortex Crossbars

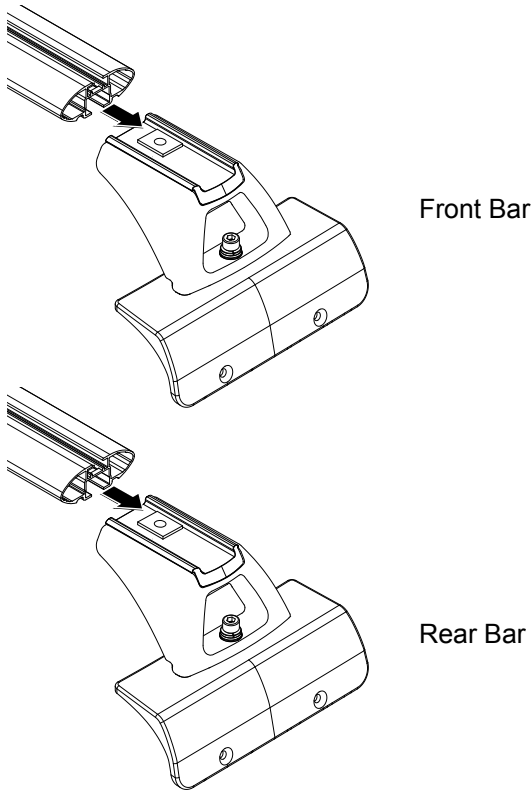

Heavy Duty Crossbars

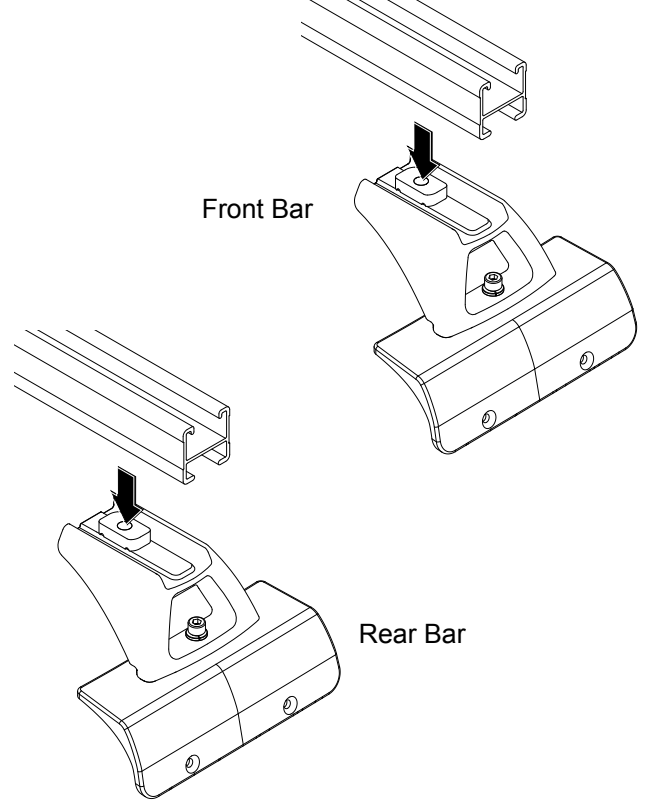

17 Adjust crossbar overhang to be equal on both sides. Tighten M6 crossbar bolts to 3-4Nm/ 2-3lb/ft. Tighten M6 security screws to 3-4Nm/ 2-3lb/ft.

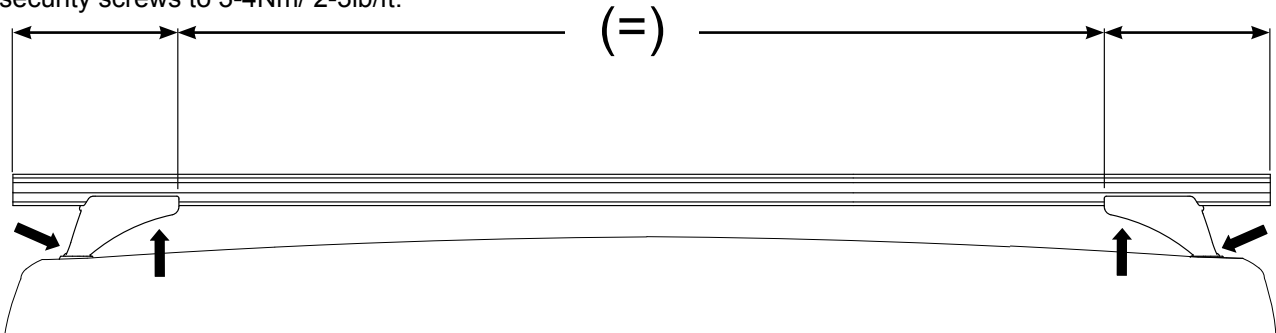

18 Insert vortex rubber and end caps into all crossbars.

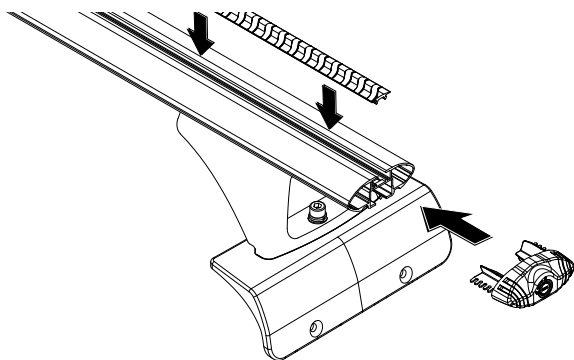

19 Measure the under bar slot length each side of the leg. Cut under bar strips to fill the gaps.

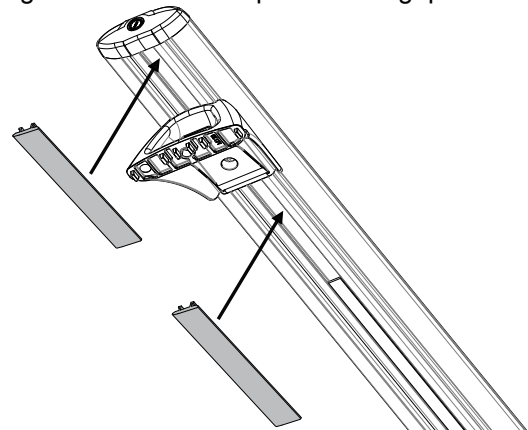

Note: RE-CHECK ALL FASTENERS ARE SECURE.