



# RHINO-RACK®

## Pioneer Wind Fairing Instructions

RWFS / RWFL

**Important:**

1. Check the Rhino-Rack website to ensure you have the latest issue of these instructions.
2. Please refer to your fitting instruction to ensure that the accessory is installed in the correctly.
3. Check the contents of kit before commencing fitment and report any discrepancies.
4. Place these instructions in the vehicle's glove box after installation is complete.
5. These instructions must be followed for warranty to be upheld.

**Fit Time:** 60 mins

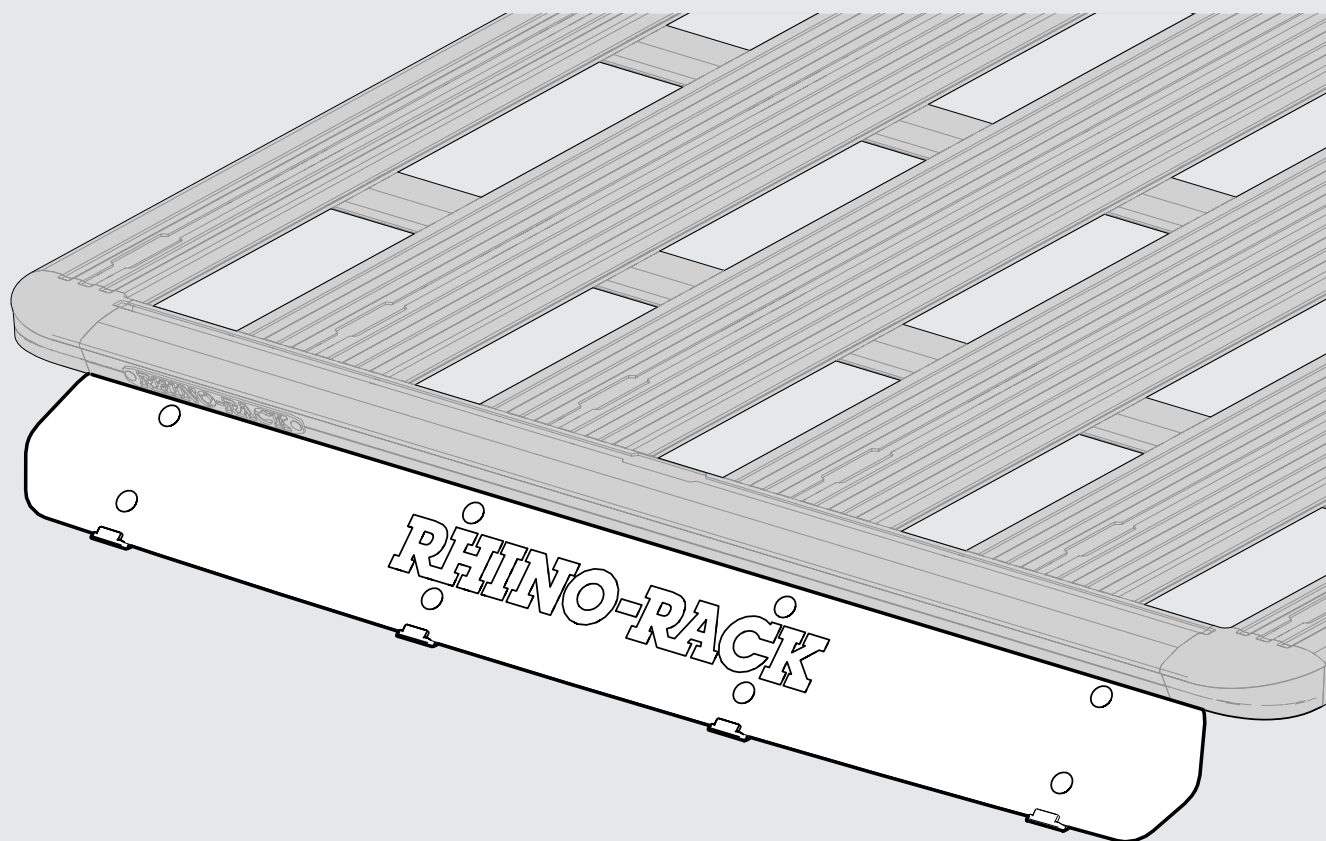

**Rhino-Rack AUSTRALIA**  
22A Hanson Pl,  
Eastern Creek, NSW, 2766  
(02) 8846 1900  
rhinorack.com.au

**Rhino-Rack USA**  
Unit D, 2450 Airport Blvd,  
Aurora, CO, 80011  
877-744-6622  
rhinorack.com

Document No: 520-RFI-00087  
Issue No: 01  
Issue Date: 13/04/2022

## RWF Instructions

---

The fairing is designed to minimise oncoming wind noise, it will not reduce all wind noise. The fairing cannot minimise noise generated from crosswinds

### Warning

---

- Do not attempt to fit the accessory to your vehicle unless you fully understand these fitting instructions. Please direct any questions regarding fitting to the dealer from where the product was purchased.
- The rack system and accessories must be removed when vehicle is put through an automatic car wash.
- Do not use fairing as a tie off point - Always lash around the platform

### Recommendations

---

- Clean fairing with a smooth cloth using water or mild washing liquid. Damage to plastic may occur with strong or concentrated cleaning detergents.
- Protect roof if concentrated or strong cleaning detergents are used as they can cause damage to paint work.

### In service maintenance checks

---

- All bolted connections should be checked after driving a short distance when you first install your roof racks & accessories.
- All bolted connections should be checked again at regular intervals (every 1000k (621mi) is recommended, depending on road conditions, usage, loads and distances travelled). All bolted connections should be checked each time they are re-fitted.

#### Torque Settings:

Unless stated otherwise in these instructions, all fasteners should be set to the following torque settings:

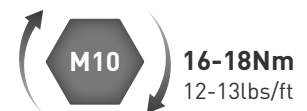

### Sensitivity to Crosswinds, Behaviour in Curves and Braking

---

Remember that the handling characteristics of your vehicle will change when transporting a load on the roof. Exercise extreme care when transporting wind-resisting loads; special consideration must be taken into account when braking.

### Note for Dealers and Fitters

---

It is your responsibility to ensure these fitting instructions are given to the end user or client. These instructions remain the property of Rhino-Rack Australia Pty. Ltd. and may not be used or changed for any other purpose than intended.

## RWFS Parts List

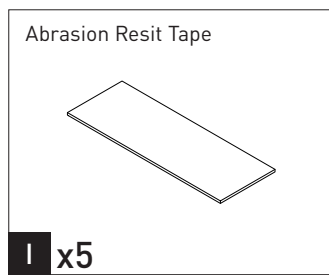
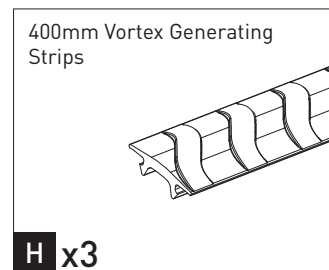
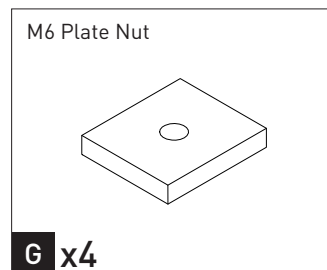
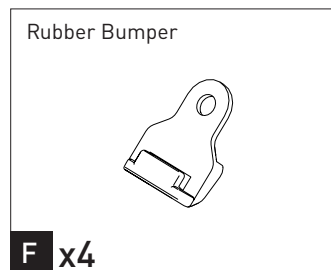
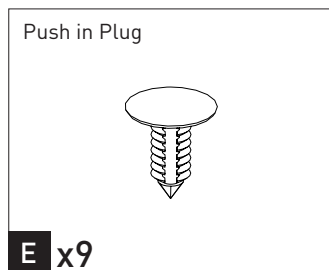
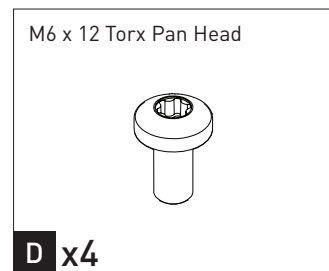
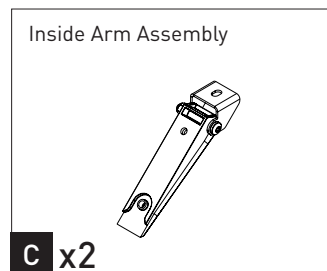
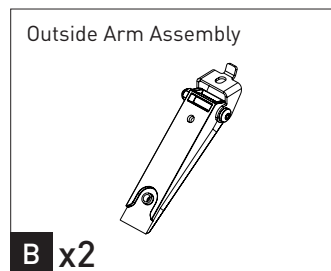
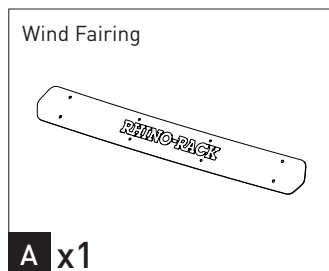

**Tools Required**  
**T1** - T30 Torx Key  
**T2** - Measuring Tape  
**T3** - Scissors  
**T4** - 13mm Socket Wrench / Spanner

## RWFL Parts List

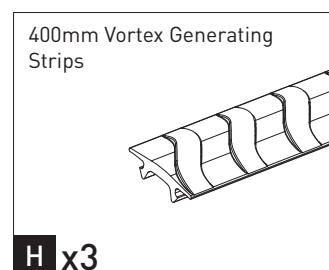
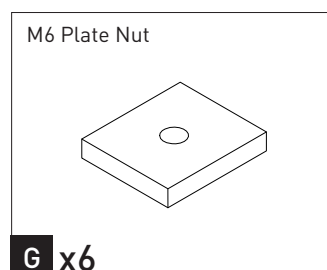
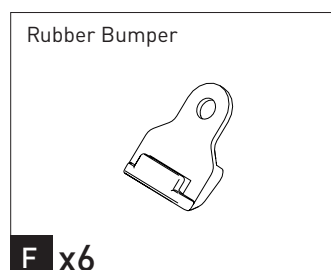
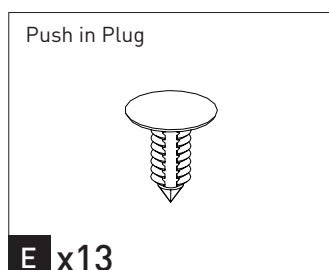
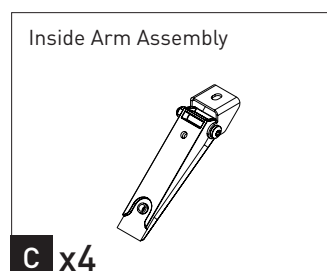
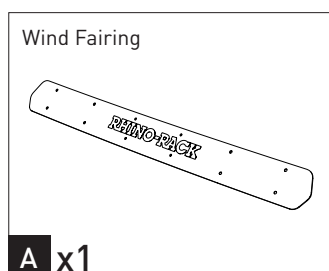

**Tools Required**  
**T1** - T30 Torx Key  
**T2** - Measuring Tape  
**T3** - Scissors  
**T4** - 13mm Socket Wrench / Spanner

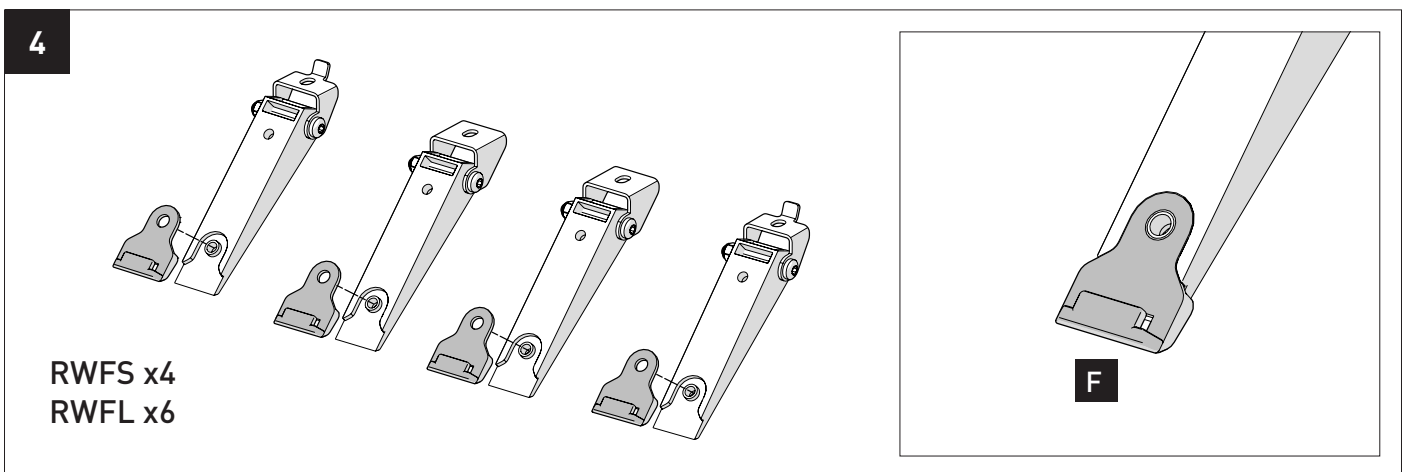
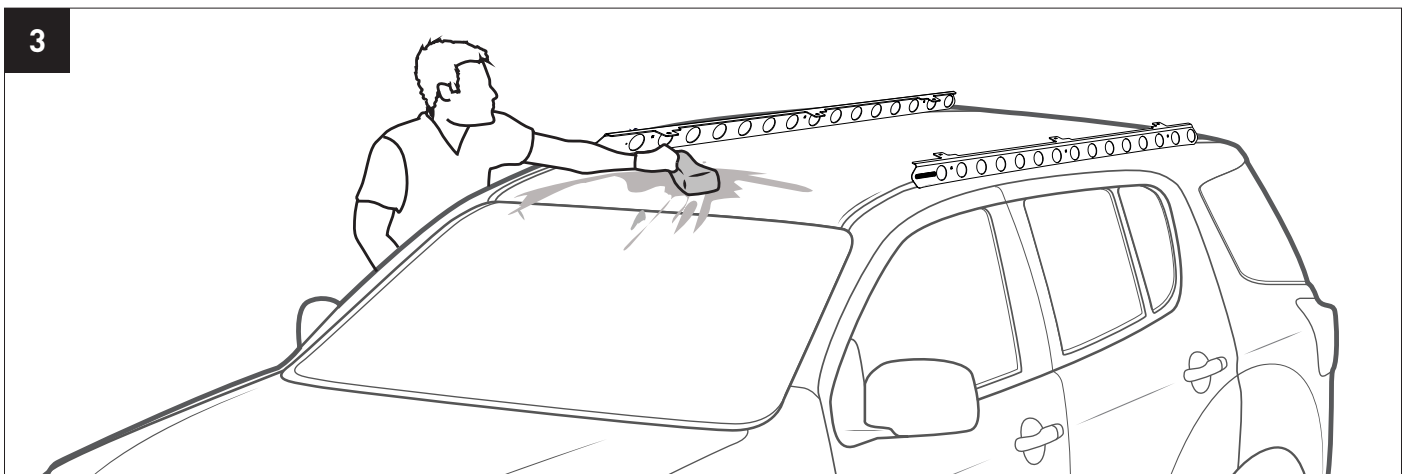
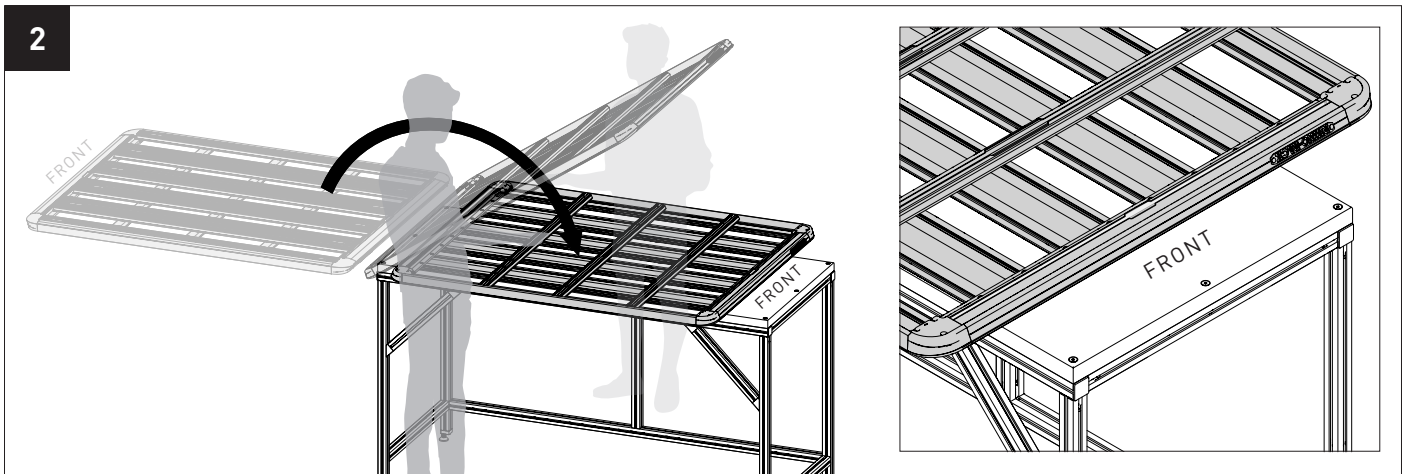
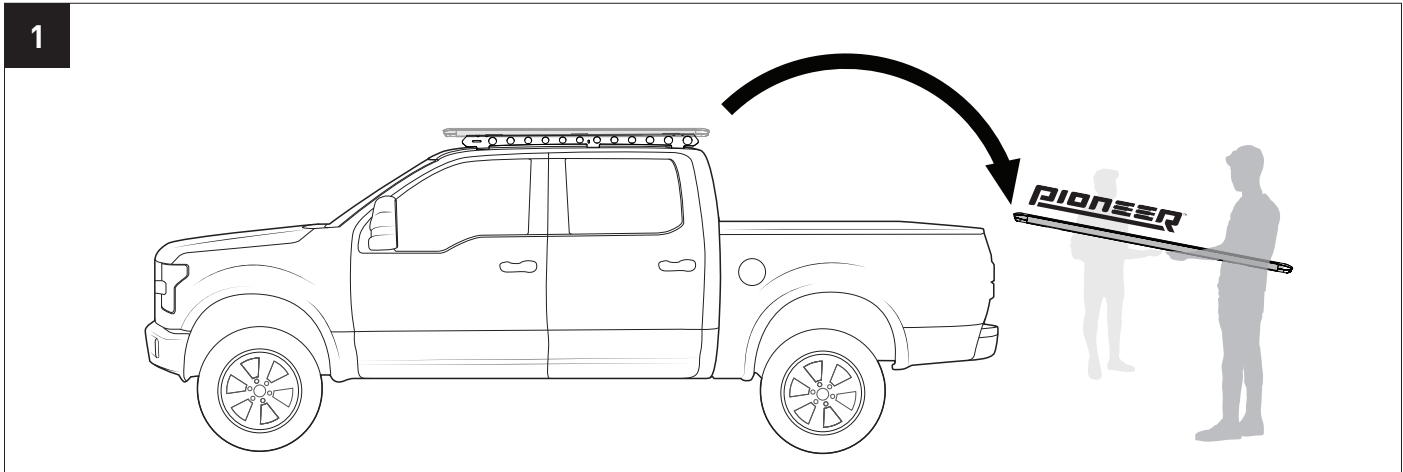

5

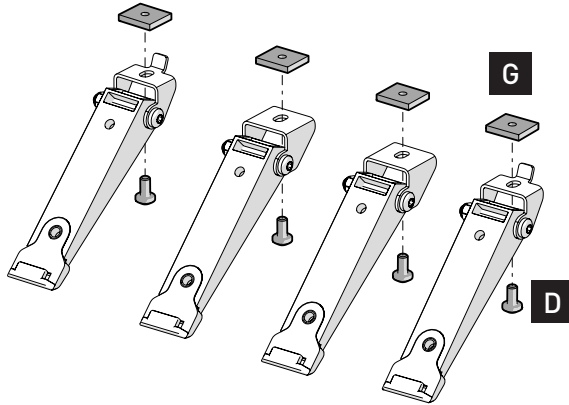

RWFS x4  
RWFL x6

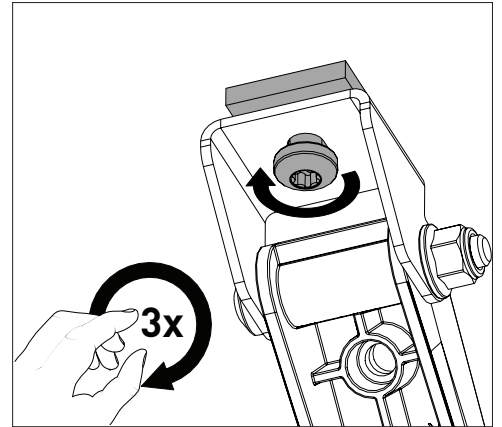

6

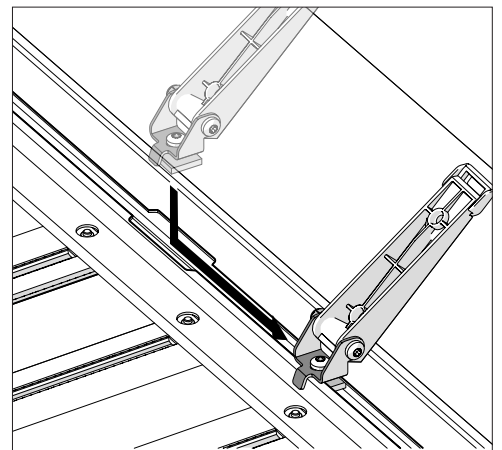
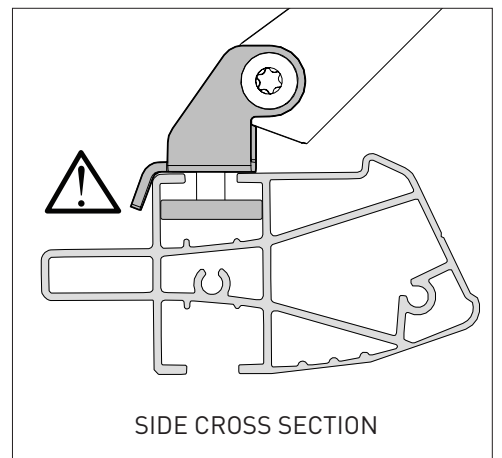
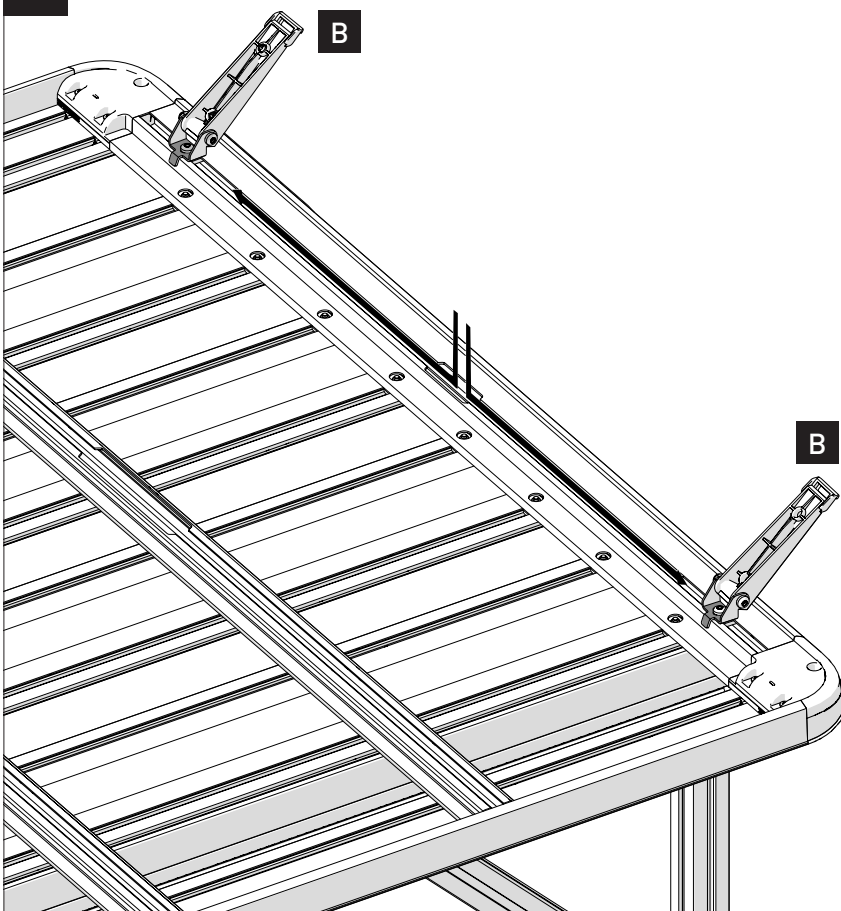

7s RWFS

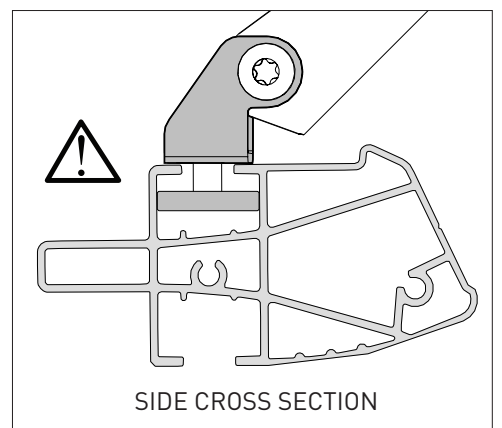
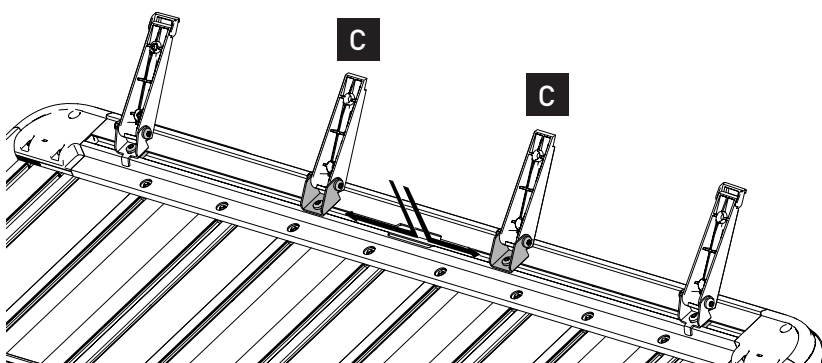

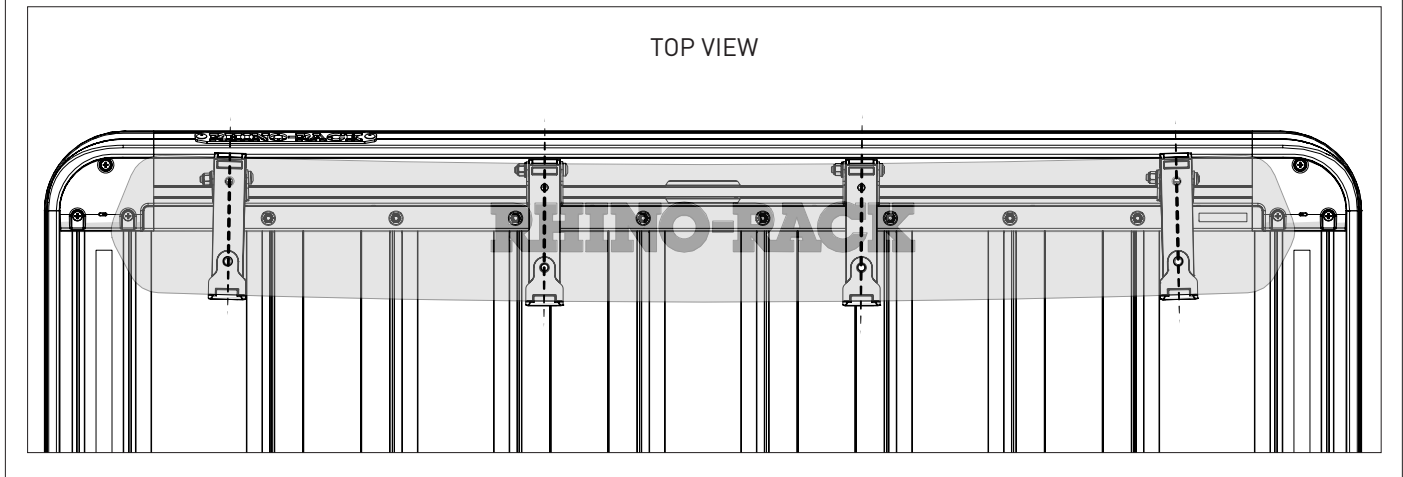
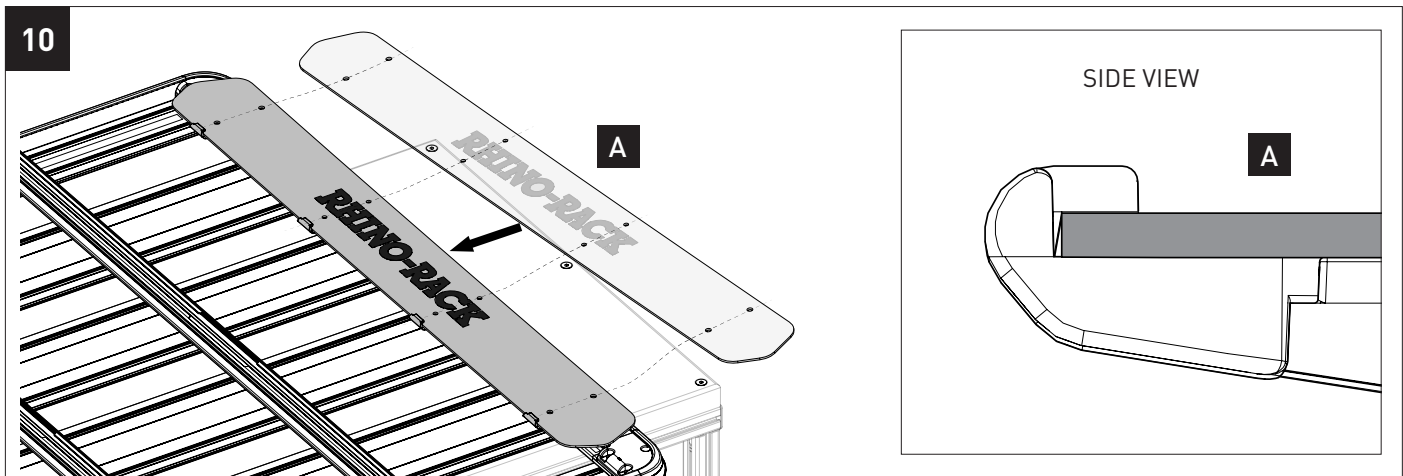
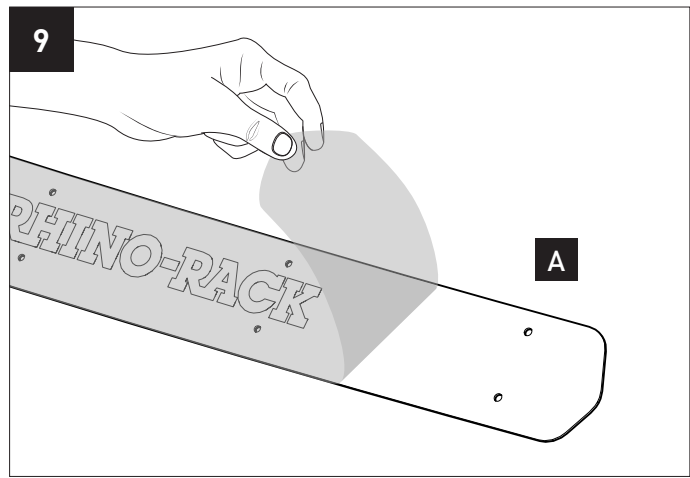
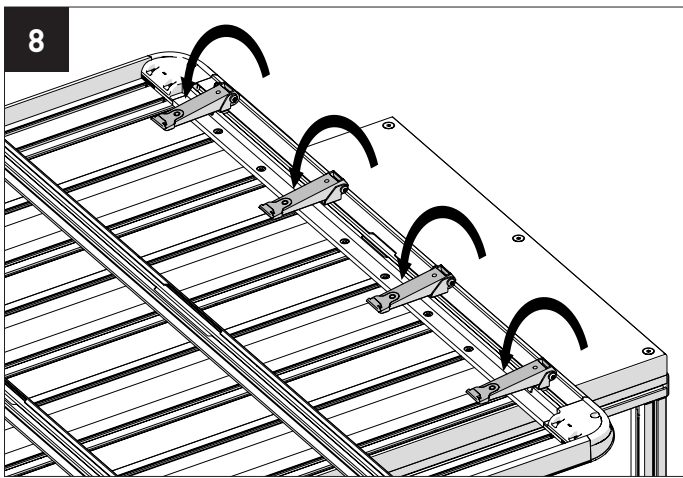
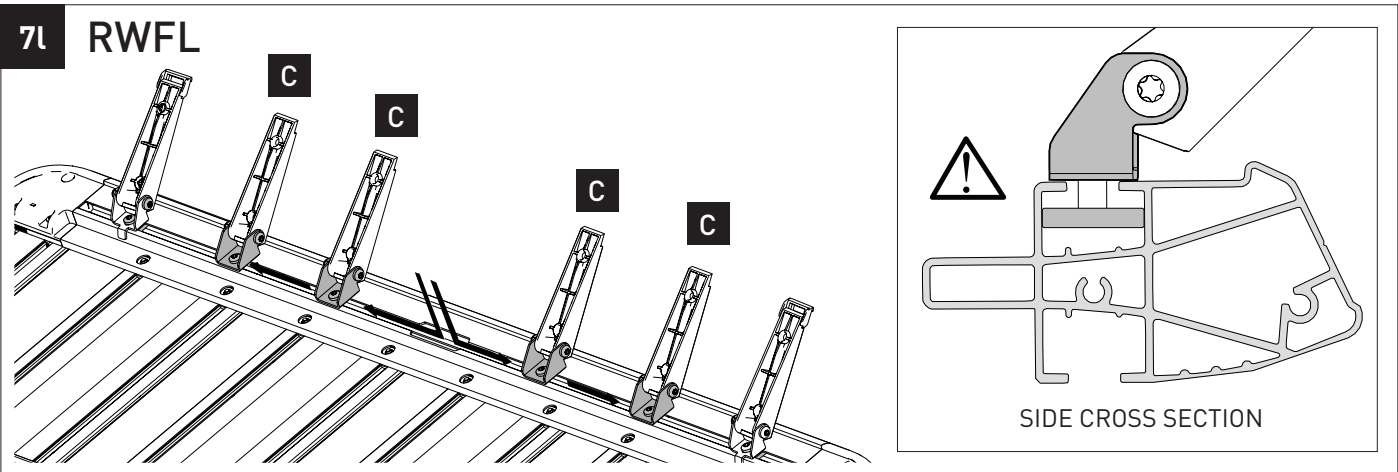

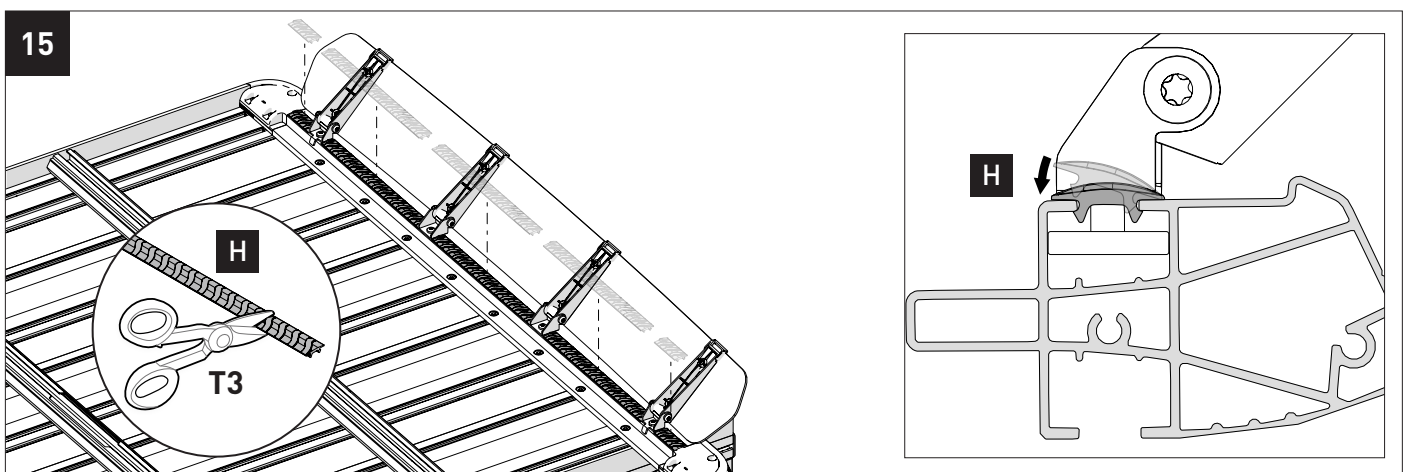
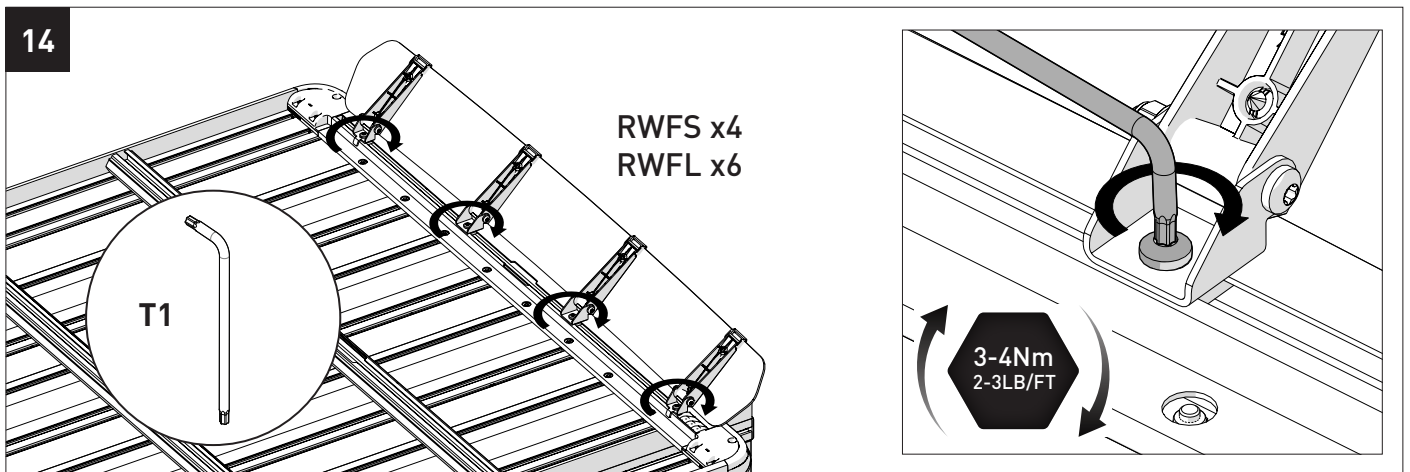
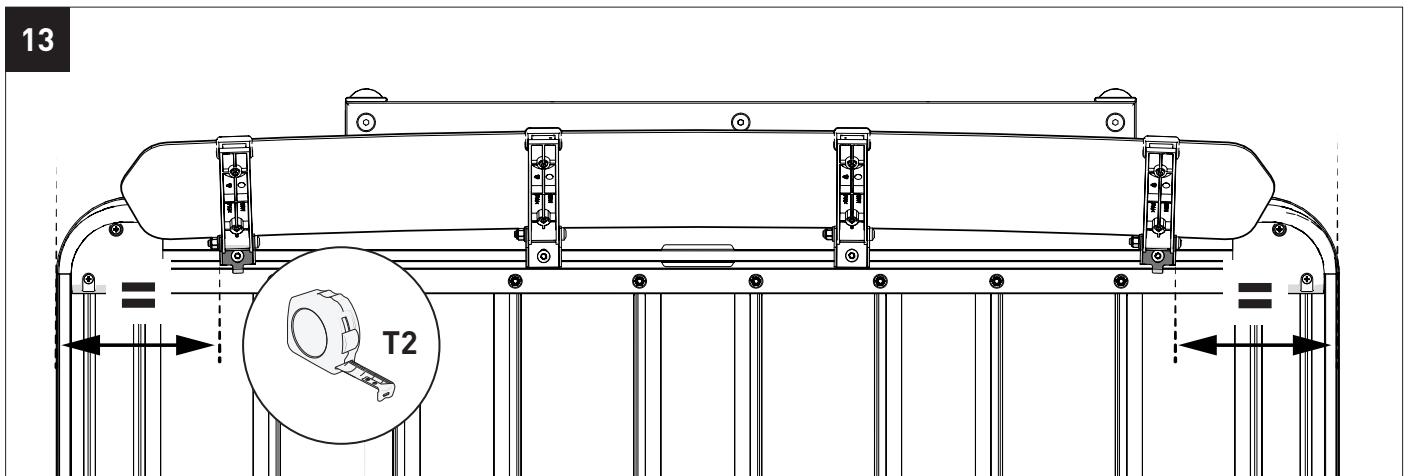
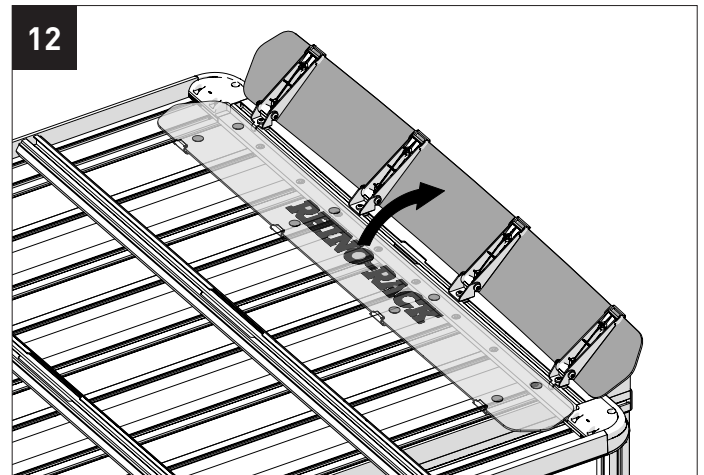
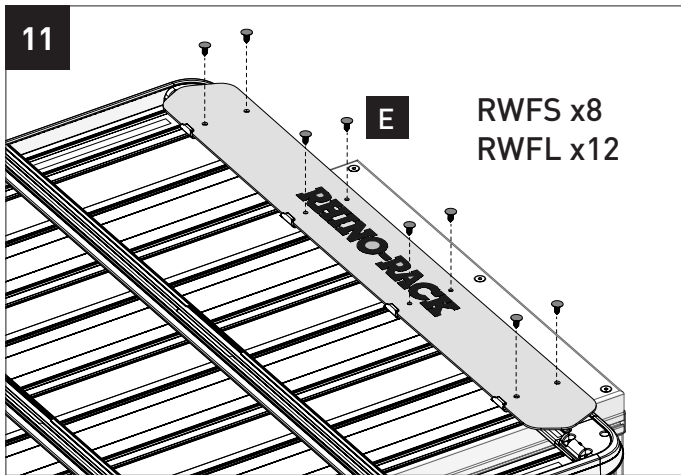

16 Reinstall to **LEG KIT**

